

Instructions for Use of High-Voltage Monolithic ICs

Be sure to read this instruction carefully as precautions for use of High-Voltage ICs including multi-chip ICs before use. After reading this instruction, keep it for future reference.

- Be sure to read the safety instructions carefully to become familiar with how they work.
- Please keep this instruction so that it is available whenever necessary for review.

IMPORTANT ANNOUNCEMENT

- The circuits, information, and other data described in this instruction are illustrative only. Please handle semiconductor devices on the basis of the specification.
In no event shall our company be liable for any damage that may result from an accident or any other cause during operation of the user's units according to this Data Sheet.
No license is granted by this Data Sheet under any patents or other rights of any third party or our company.
- In no event shall our company be liable for any failure in a semiconductor device or any secondary damage resulting from use at a value exceeding the absolute maximum rating or acts of God.
- When disposing or treating semiconductor devices or packaging materials are, comply with laws and regulations of your country or local government.
- The products (technologies) described in this Data Sheet are not to be provided to any party whose purpose in their application will hinder maintenance of international peace and safety nor are they to be applied to that purpose by their direct purchasers or any third party. When exporting these products (technologies), the necessary procedures are to be taken in accordance with related laws and regulations.

FOR SAFE OPERATION

If semiconductor devices are handled in an inappropriate manner, failures may result from it. For this reason, be sure to read "Instruction for Use" before use.

The following signs indicate safety precautions.

They are combinations of warning symbols and words DANGER, WARNING, CAUTION, and NOTE.



This is a safety warning symbols as reminders of hazards which, if not avoided, may cause a personal injury or death. Please follow warning messages to avoid possible injury or death.



DANGER: This alerts users to the risk of serious personal injury or death.



WARNING: This alerts users to the possible risk of serious personal injury or death.



CAUTION: This alerts users to the possible risk of personal injury.

NOTICE: This alerts users to the possible risk of property damage (except personal injury).

(NOTE): This does not indicate safety precaution but useful information.

【SAFETY PRECAUTIONS】

- Regardless of changes in external conditions during use "absolute maximum ratings" should never be exceeded in designing electronic circuits that employ semiconductors. In the case of pulse use, furthermore, "safe operating area (SOA)" precautions should be observed.
- Semiconductor devices may experience failures due to accident or unexpected surge voltages. Accordingly, adopt safe design features, such as redundancy or prevention of malfunctions, to avoid extensive damage in the event of a failure.
- In cases where extremely high reliability is required (such as use in nuclear power control, aerospace and aviation, traffic equipment, life-support-related medical equipment, fuel control equipment and various kinds of safety equipment), safety should be ensured by using semiconductor devices that feature assured safety or by means of user's fail-safe precautions or other arrangement. If you have any questions, contact our sales department staff.



WARNING

If semiconductor devices fail, there may be cases in which the semiconductor device, wiring or wiring pattern will emit smoke or cause a fire or in which the semiconductor device will burst.

- When testing or measuring semiconductor devices, cover them or wear protective equipments.
- Do not store flammable or combustible materials in the vicinity of devices.
- Do not use semiconductor devices in places where there is a risk of explosion and fire.
- When a semiconductor device fails, cut off its power supply.



CAUTION

The temperature of semiconductor device becomes high during operation and for a while even after power is turned off. The hot device may cause a burn injury. Care should be taken when testing or measuring a semiconductor device.

- When handling a semiconductor device, make sure that voltage is not applied.
- When handling a semiconductor device, make sure that it is cool or wear protective equipments not to get burned.

FOREWORD

- This instruction explains general handling of High-Voltage ICs including multi-chip ICs for design engineers and quality assurance engineers.
- Read and fully understand the descriptions and the warning given in this instruction before use. Also, read individual product specifications with this instruction.
- If semiconductor devices are handled in an inappropriate manner, failures may result from it. This instruction explains precautions to handle High-Voltage ICs(products) including multi-chip ICs in safety.
- The individual specifications and dimensions, etc. stated in this instruction are subject to change without prior notice to improve products characteristics. Refer to the following website for the latest information. Consult our sales department staff if you have any questions.

【Latest Information】

<https://www.minebea-psd.com/en/products/ic/index.html>

- This Data Sheet may not be reproduced or duplicated, in any form, in whole or in part, without the expressed written permission of our company.

Contents

1. Device selection	• • • Page 1
1.1 Maximum ratings	
1.2 Derating considerations	
2. Precautions in system design	• • • Page 2
2.1 Input capacity	
2.2 Rise time and fall time of the input wave form	
2.3 Power supply line filter	
2.4 Power supply sequence	
2.5 Part arrangements and environment	
3. Circuit design	• • • Page 3 - 5
3.1 General considerations	
3.2 Countermeasures against noise and voltage surges	
3.2.1 Countermeasures for noise elimination	
3.2.2 Countermeasures against surges	
3.2.3 Influence of strong electric fields	
3.2.4 Treatment of unused pins	
3.2.5 Precautions for multiple power supplies	
3.2.6 Latch-up	
4. Inspection and measurement	• • • Page 5 - 6
4.1 Precautions against static electricity	
4.2 Preventing destruction due to bad electrical contact of connector or others	
4.3 Power surge and residual charge	
4.4 Precautions against noise and oscillation	
4.5 Precautions when connecting a measuring circuit	
4.6 Leakage from electrical facilities	
4.7 Semiconductor package breakage due to a handler	
4.8 General precautions	
5. Precautions against static electricity	• • • Page 6 - 7
5.1 General precautions against electrostatic discharge (ESD)	
5.2 Cautions on handling devices	
6. Precautions for device installation	• • • Page 7 - 12
6.1 Lead forming and cutting	
6.2 Handling surface mount packages	
6.3 Mounting on printed circuit boards	
6.4 Soldering	
6.4.1 Pin insertion device (wave soldering bath / flowing solder bath)	
6.4.2 Surface mount devices (reflow bath)	
6.5 Cleaning methods	
6.6 Mounting on heat sinks	
7. Packaging / storing	• • • Page 13 - 15
7.1 Packaging precautions	
7.2 Storage methods for semiconductor devices	
7.3 Precautions in moving and transporting	

1. Device selection

1.1 Maximum ratings

The values listed in the maximum rating tables are absolute maximum ratings, and are not to be exceeded under any conditions. If the maximum ratings are exceeded even momentarily there is a possibility of degradation or destruction. Absolute maximum ratings should never be exceeded regardless of changes in external conditions, since operation above absolute maximum rating values can shorten the life of a device a great deal. Caution must be taken that whole conditions are not adequate even if the conditions of each item of absolute maximum ratings are met. For example, the voltage and current applied to a transistor may each be below the maximum ratings, but the power consumed is the product of the two and must be within the permitted collector loss for that transistor. This applies not only to direct current maximum ratings, but also to pulse use where the safe operating area (SOA), load locus, peak voltage, and current must be considered.

1.2 Derating considerations

If a device is used under overload conditions, there is a possibility that reliability will be significantly decreased even if absolute maximum ratings are not exceeded. Determining the derating degree for absolute maximum ratings is an important problem in reliability design. Although derating items to be considered at the system design stage vary slightly depending on the device type, they include electrical stress deratings such as voltage, current, power, load, and environmental stress such as temperature and humidity, and mechanical stress deratings for vibration or shock.

Consideration of derating standards is desirable at the device design stage to ensure reliability. When designing within standards is difficult, other steps become necessary such as selecting a device with higher absolute maximum ratings. Please consult our technical department beforehand. Derating standards that should be considered for reliability design are shown in Table 1.

Table 1 Examples of derating design standards (Note 1)

Derating factor (Note 2)		IC condition
Temperature	Junction temp. (Note 3)	Under 110°C (Under $T_j = 60^\circ\text{C}$)
	Device ambient temp. (Note 3)	$T_{\text{op min}}$ to $T_{\text{op max}}$ ($T_a = 0$ to 45°C)
	Other	Power consumption (P_d), ambient temperature (T_a), heat radiation conditions / heat resistance (θ_{ja}) $T_j = P_d \times \theta_{ja} + T_a$
Humidity	Relative humidity	RH = 40 to 80%
	Other	If there is condensation due to a quick temperature change, the printed circuit board is coated by moisture-resistant protection.
Voltage	Breakdown voltage	Follow catalog recommended operating conditions. When high-voltage is applied between pins, protect against breakdown by circuits for excessive voltage absorption or other methods.
	Excessive voltage	Use preventative measures for excessive voltage application including electrostatic destruction.
Current	Average current	$I_c \times 0.5$ or below (especially power IC)
	Peak current	$I_c (\text{peak}) \times 0.8$ or below (especially power IC)
	Other	Give consideration to current drivability and load and wiring impedance.
Power	Average power	Maximum rating $\times 0.5$ or below (especially power and high frequency ICs)
Pulse (Note 4)	SOA	Do not exceed individual product specification absolute maximum rating values.
	Surge	$I_c (\text{peak})$ or below

- Notes: 1. Except for special use conditions. (Please consult our technical department.)
 2. Fulfill as many of these derating factors as possible simultaneously.
 3. The values in parentheses apply to high-reliability use.
 4. For transient conditions, derate with the above standards for reference using less than the maximum ratings of voltage, current, power, and junction temperature including surges. If you have any questions, please consult our technical department.

2. Precautions in system design

2.1 Input capacity

If the input circuit has a CMOS configuration, electrostatic capacity exists between the input and the ground. The main part of that capacity is between the gate and the substrate, but the capacities of the package and the lead and of the input protective circuit are added to it. Changes of input capacity based on input voltage are principally attributable to gate to substrate capacity, and the input voltage is usually about 15pF or less.

2.2 Rise time and fall time of the input wave form

If the input circuit has a CMOS configuration, the rise and fall time of the input wave form is to be 100ns or less (during when $V_{CC}=4.5V$), unless specifically provided for. Because the input/output characteristic of the CMOS IC is that the voltage amplification ratio is extremely high near the threshold, there are cases in which, if only a slight ripple component is added to the input voltage, the output operation will become unstable.

2.3 Power supply line filter

For purposes of noise decoupling or noise filtering, insert a capacitor of about 1 μ F between the power sources (both low-voltage and high-voltage power sources) and the ground. It must be noted that there is a possibility that oscillations may occur if a device having parasitic inductance is inserted on a wiring where a principal current flows or on a ground side.

2.4 Power supply sequence

Because our high-voltage IC is composed of low-voltage and high-voltage devices in a single chip, it is designed to operate on at least two power supply types: high-voltage power supply and low-voltage (usually 5V) power supply. Unless the sequence of power application is specified, be sure to arrange regarding the application that low-voltage power should be supplied first, to be followed by successively higher voltage power supply. Make sure that no input signal is given until after all the types of power are supplied. In turning off the power supply, on the other hand, the reverse should be carried out, i.e., turn-off high-voltage power first, then, successively, lower voltage power. Confirm power supply sequence by seeing the waveform at the device pin since an actual power supply sequence depends on the power supply circuit of the system. In case of control with a mechanical relay, operate the relay without the applied voltage.

2.5 Part arrangements and environment

Semiconductor device reliability and characteristics vary according to environmental conditions. Therefore, semiconductor device positioning within the system based on temperature and heat dissipation conditions must be carefully examined to maintain reliability.

- (1) Heat radiation sources such as large resistors near semiconductor devices will add heat directly to the heat sinks or the devices; abnormal heat will lower reliability. Give consideration to ventilation during positioning.
- (2) Dust easily accumulates near high-voltage circuits and in lower corners. Insulation degradation or malfunction may sometimes occur in semiconductor devices that are mounted in such places, due to dust affixation. Take countermeasures include coating the printed boards and semiconductor devices with a water-repellent insulating resin.
- (3) Malfunction caused by short circuit between the board wiring and semiconductor pins due to conductive foreign matter (soldering or plating scraps), noise generation due to dust accumulation, moisture absorption, and condensation, and trouble due to a large current leakage, whisker, and corrosion. Board coating is extremely important under harsh conditions such as high humidity, condensation, and dust accumulation to ensure reliability over long maintenance-free periods. When using coating materials with surface mount products, it must be noted that stress arising from resin hardening, contraction stress, or the heat expansion coefficient difference with the board can cause device breakage, cracks, or disconnections in solder sections between the leads and the boards.

3. Circuit design

A reliable circuit design first must fulfill the initial characteristics, then margins must be designed in by applying derating and considering the variable characteristics.

3.1 General considerations

- (1) Make every effort to keep the area near semiconductor devices like ICs, transistors, etc. at a low temperature.
- (2) Keep supply voltage, input voltage, and power consumption within rated values, and consider derating.
- (3) Avoid causing or applying unnecessary excess voltage at the input, output, and power supply pins. Leave sufficient space around the area applied high voltage.
- (4) If plastic molded semiconductors are placed in a strong electric field, polarization of the plastic material and passivation film results, causing possible errors in operation. Also, strong electromagnetic fields sometimes cause incorrect operation and localized heat radiation, so use a shield in strong electric or magnetic field environments.
- (5) Radiation entering the IC may cause transient noise, sometimes resulting in a malfunction. Separate the IC from radiation sources or use with shielding.
- (6) In case IC electrical characteristics are described for ordinary temperatures (25°C), consider characteristic changes in the actual operating temperature range.
- (7) Prevent a voltage imbalance in power supply on/off times. For example, if voltage is applied to the input or power supply pins while the circuit ground pin is floating, excessive stress is added.

3.2 Countermeasures against noise and voltage surges

Voltage surges, static electricity, and noise are problems common to all semiconductor devices; countermeasures are necessary to remove or reduce the factors in their occurrence. Electronic appliances are generally designed on the premise that the output from commercial power supplies varies $\pm 10\%$. However, failures or malfunctions may still be caused by supply voltage changes. If electromechanical devices in which surges may occur are used nearby, they can cause problems as surges are built up in the supply line. Lightning may also cause an impulse surge. These can be reduced by placing a filter on the AC line side such as that shown in Fig. 1. Shield the area where surges could enter the circuit board parts or semiconductor devices directly except AC line. A shield's impedance to ground must be low; if it is not, it is ineffective.

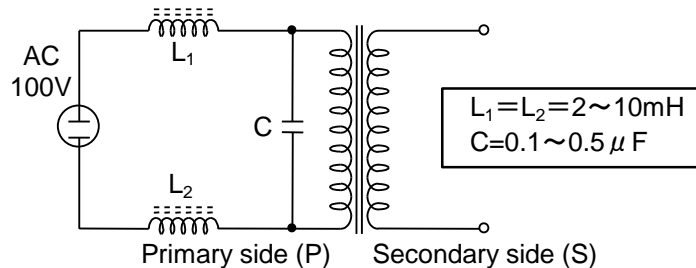

Fig. 1 Surge suppressor circuit example

When there is a risk of noise such as directly applied surge pulses, use protective circuitry as shown in Fig. 2. The RC time constant should be in a range that does not affect operation but absorbs surge pulses.

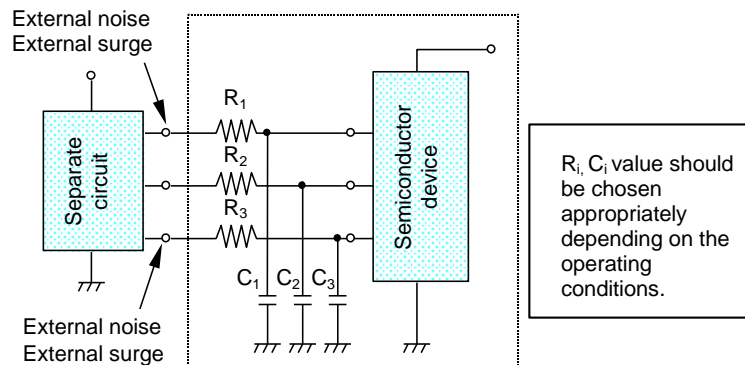

Fig. 2 Surge protection circuit example

3.2.1 Countermeasures for noise elimination:

To build a system in which noise is not a problem, necessary countermeasures include finding noise sources in order to reduce or eliminate them, designing against noise pick-up, using circuits with a large noise margin, or establishing corrective circuitry.

(1) Countermeasures against noise sources

The highly effective countermeasure is to address the noise-generating source when possible. This is done by reducing surge voltages with a relay coil in parallel with a diode, or by installing resistors and capacitors. For noise on the AC line, place a filter in the power supply line on the generating source side. Also, for devices that produce strong electrical fields, if the generating source side is shielded, fewer countermeasures are needed in the side (whole system) receiving the interference. Other possible treatment such as separation from the generating source can also be considered. For electromagnetic noise generated by the equipment, caution considering towards outside system is also necessary as this should publicly be regulated as electromagnetic interference waves.

(2) Countermeasures through ground lines

Establishing a ground line dedicated to the circuit system completely separate from such ground systems as those of other power supply lines eliminates interference in the circuit system due to current flowing in the ground system. Also, an having only one contact point between the circuit system and its case prevents the formation of a ground line closed-loop between them (Fig. 3).

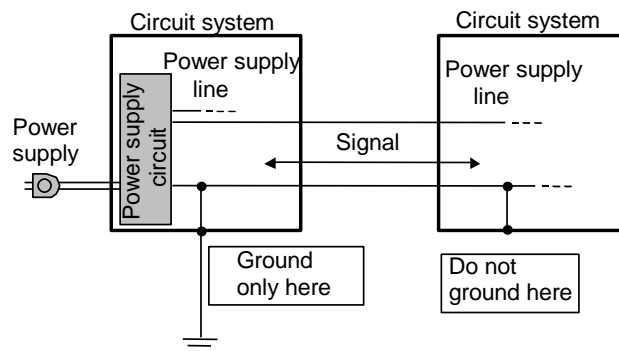

Fig. 3 Circuit system grounding

3.2.2 Countermeasures against surges:

Circuit systems are sometimes placed in environments where voltage surges tend to take place; some major examples are shown here.

When a high-voltage circuit is near the ICs or transistors like in a system containing a CRT or an ignition, voltage surges sometimes occur, due to discharge. Surge voltage reduction is a big factor in improving reliability. Fig. 4 shows a circuit in a power supply to absorb surges. Finding the surge intrusion route and pin and taking the above countermeasure using a protection device are necessary to prevent destruction of the semiconductor device by a surge.

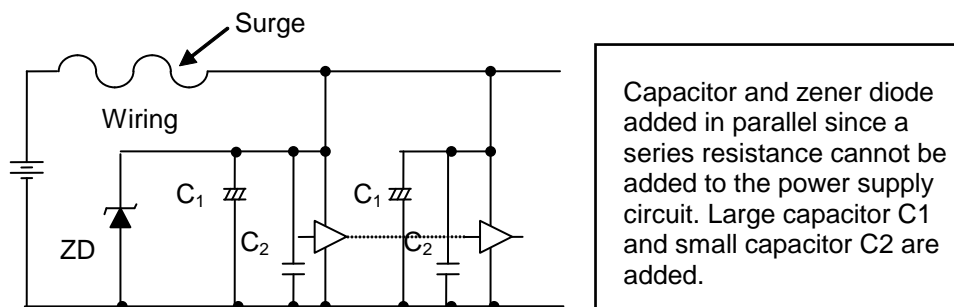

Fig. 4 Power supply line surge absorption

3.2.3 Influence of strong electric fields:

Because MOS device operation is controlled by electrical fields, the device package itself polarizes and charges up if a strong electric field is applied from outside for a long period of time. This may change the device threshold voltage, sometimes resulting in characteristic degradation.

3.2.4 Treatment of unused pins:

If ICs are operating with unused input pins exposed, malfunction may sometimes occur due to crosstalk with other circuits. Input pins not in use should be either grounded through an appropriate impedance or connected to the power supply line. In installation board design, NC pins should not be used as signal relay points. They should be connected together to the power supply line or the ground, or left open.

3.2.5 Precautions for multiple power supplies:

For ICs requiring multiple supplies (+5V, +12V, etc.), IC destruction sometimes results from the power supply on or off sequence not being in order. Be careful of noise generation if there are many ground pins. (Refer to section 2.4 Power supply sequence.)

3.2.6 Latch-up:

The latch-up phenomenon is a problem peculiar to CMOS. This potentially destructive phenomenon occurs when there are unexpected surges exceeding maximum ratings, current ripples, regulation or noise, or if the device is operated with two power supplies not starting up simultaneously. Consequently, sufficient consideration must be given to latch-up prevention during system design.

4. Notes on inspection and measurement

When semiconductor devices are measured or inspected, the consideration including above-mentioned points and the precautions for inspection circuit design in section 2, 3, and the precautions in 5 Precautions against Static Electricity below is required. Pay special attention to the following points.

4.1 Precautions against static electricity:

During semiconductor measurements all pins are open and the possibility of each pin independently contacting persons, measuring instruments, handlers, or workbenches increases. Device destruction due to static electricity is possible. Care is especially necessary in automatic measuring using a handler, where static electricity easily occurs when the semiconductor slides along the magazine or guide rail. Also, Avoid repeated use of magazines coated with anti-static treatment as the magazine anti-static treatment may lose its effectiveness.

4.2 Preventing destruction due to bad electrical contact of connector or others:

It must be noted that the bad connections of a socket, connector, or others sometimes cause an improper power supply input sequence, abnormal voltage during current drive, or device destruction due to chattering. Replace sockets and connectors regularly.

4.3 Power surge and residual charge:

Take care that voltage surges do not occur, especially from the tester during measurement, or take countermeasures such as adding clamping circuitry to the power supply circuit of the tester. When intermediate inspections with board testers or in-circuit testers are being carried out, semiconductor devices may be destroyed if the next board is tested while the capacitors on a tester board are still charged. Also, in the case where capacitors on a circuit board where a semiconductor device is mounted remain charged after a test, there is a possibility of discharge, so make sure to discharge by inserting a discharge resistor.

4.4 Precautions against noise and oscillation:

It must be noted that even in circuits that normally operate correctly, load capacity becomes large due to the connection of oscilloscope probes or measuring instruments during measurement, and circuits may operate incorrectly due to noise or oscillation, causing semiconductor destruction.

4.5 Precautions when connecting a measuring circuit:

 CAUTION
<ul style="list-style-type: none">• When a power supply system is floating, a floating measurement or instrument should be used as well. There is a risk of short circuits.• There is a danger of electrical shock if persons are grounded during operation.

It must be noted that while a power supply system of a product is floating, if a grounded measuring instrument is connected, there is a risk of fire due to short circuits. In this case, it is necessary to use measuring instrument itself under the floating condition, but there is a danger of electrical shock during operation.

4.6 Leakage from electrical facilities:

Make sure that there is no current leakage through the pins or chassis of the curve tracer, oscilloscope, pulse generator, or DC voltage regulator from AC power supplies.

4.7 Semiconductor package breakage due to a handler:

When inspections are carried out with a probe such as an in-circuit tester, be careful to avoid excessive stress on the semiconductor package. There is a special danger of package destruction or solder crack.

4.8 General precautions:

When inspection of product is performed manually, prevent abnormalities such as pin misconnection, reverse insertion, and short circuits between pins. When checking product board operation, confirm that there are no short circuits between pins due to solder or foreign particle before powering up for the check.

5. Precautions against static electricity

5.1 General precautions against electrostatic discharge (ESD)

Caution is necessary in handling IC devices since they are generally susceptible to destruction through electrostatic discharge. Because the possibility of electrostatic destruction is especially high in the cases listed below, countermeasures after confirmation of the conditions are necessary.

(1) When the device is contacted with the conductor:

When the device is contacted with the conductor such as metal objects, the danger of device destruction due to sharp discharges is higher. Contact of devices with metal must be avoided as much as possible, but when unavoidable, the metal should be grounded and the charge must be removed from the device.

(2) When the device receives friction:

Packages become charged when the device is subjected to friction. Prevent friction or suppress the amount of charges by changing the material where friction occurs and removing charges.

(3) When using tools:

When charged tools are brought in proximity to devices, the device will be charged through electrostatic induction. Tools must be prevented charging (removed charges) or replaced by those of anti-static materials.

(4) When the humidity of the surrounding area drops:

When humidity drops in the device-handling location, devices become charged easily. Especially in the location where only devices (before being installed) are handled, effectiveness can be expected if humidity is controlled. (See section 5.2.)

5.2 Cautions on handling devices

(1) Working environment:

Static electricity occurs easily when the relative humidity drops. Surface mount devices must be stored in a dry atmosphere to prevent moisture absorption, but maintain relative humidity at 45 to 75% with humidifiers during the board mounting process. When humidifying with humidifiers, use deionized water or cooled-down boiled water as chlorine in tap water may cause nozzle clogging, rusts on devices and their leads. If it is difficult to control humidity, removing charge with air ionizing blowers (ionizers) is effective. Be careful of ion balance in using them. The unbalanced ion may charge devices.

(2) Work:

At the work site, easily charged insulators (especially chemical fiber and plastic products) must be avoided as much as possible. When handling semiconductor devices, it is necessary to use materials for electrostatic countermeasures or anti-static containers (for example, electrostatic shield packing, anti-static mats, etc.) in storage and transport.

(a) Equipment and facilities

To prevent electrostatic accumulation, thoroughly ground measuring and test equipment, conveyors, work platforms, floor mats, tools, and soldering baths and irons. Cover workbenches and floors with anti-static mats ($10^5\Omega/\square$ to $10^9\Omega/\square$) and ground them.

(b) Workers

Wear anti-static clothes and gloves. Put earth bands directly on the skin not to charge workers. It must be noted that shoes or sandals, with resistance of 1 to $100M\Omega$ are regarded as adequate, but this resistance can change due to dirt, wear, or humidity.

(c) Work methods

Remove charges with ionizers especially in places where discharge phenomena of charge or static electricity are detected. Use a soldering iron for semiconductors, and ground the iron tip.

6. Precautions for device installation

For assembly and installation of semiconductor devices, there are precautions to be considered in designing structures and installing the devices. The followings take installation work as an example and explain the precautions. Take care with these handling and installation methods to ensure semiconductor device reliability.

6.1 Lead forming and cutting

Before installing semiconductor devices onto printed boards, it is sometimes necessary to form or cut leads, but if unnecessary force is applied, device destruction or shortened life can result. For example, if relative stress is applied between the device package and its leads, internal connections can break or a gap which damages the hermetic seal and lowers reliability can open between the body and leads. In the worst case, the mold resin or glass will break. Therefore, take care regarding the following points when forming or cutting leads:

- (1) When forming and cutting leads, hold the leads between the body and the bending (cutting) point to avoid placing stress between the body and leads. When using a metal pattern to process large quantities, establish a lead fixing mechanism and keep the lead pressing mechanism from adding stress to the device body. Establish the mechanism which holds surrounding of the body and does not place stress on the chip (typically the center of the body). Do not hold the upper part of the chip with a metal pattern.
- (2) When bending leads at a right angle, bend at a point at least 3 mm from the body. Avoid bending more than 90° . When bending to an angle less than 90° , bend at a point at least 1.5 mm from the body.
- (3) Do not bend leads repeatedly.
- (4) Do not bend leads in the thick direction.
- (5) Devices are sometimes destroyed by excessive stress (pulling, etc.) in the axial direction, so be certain to keep forces within prescribed values.
- (6) Be careful of dirt and scratching on lead line plated surfaces due to bending jigs or tools.

6.2 Handling surface mount packages

For surface mount devices, the device installation sides of a printed board are heated first, so they have a structure susceptible to heat stress during installation.

When epoxy resin used in plastic packages is stored in high humidity areas, moisture absorption is unavoidable. If a large amount of water is absorbed, it quickly turns into steam during solder installation, which causes resin/lead frame surface separation and, in some cases, package cracking. Therefore, store surface mount packages in a dry atmosphere. For products requiring moisture absorption control, anti-moisture packaging is used for shipping and storage. To avoid reabsorption after opening anti-moisture packaging, store products away from high temperature and high humidity and complete installation within specified storage time. The environmental conditions and the specified time are ranked based on strength in high temperature of products. For storage after opening, insert silica gel free of absorbed moisture (for which blue color indication can be confirmed), reseal and store. To remove moisture absorbed during shipping, storage, or handling, baking for 16 to 24 hours (for 4 to 24 hours for ultra-slim packages such as TQFP, TSOP) at 125°C with constant-temperature oven is recommended. Bake at 125°C before solder installation in the following cases:

- (a) When a blue color indicator placed in a desiccant (silica gel) cannot be seen.
- (b) When specified storage time has elapsed.
- (c) When individual specifications state baking before installation.

For devices in non-heat resistant shipping magazines, trays, tape and reels, devices must be transferred to heat resistant containers before baking. Trays marked "Heatproof" can be baked. However, avoid baking items still in their anti-moisture packaging pouch. To prevent tray warping, place trays on a flat board, bake, and cool slowly.

6.3 Mounting on printed circuit boards

When mounting semiconductor devices on a printed board, take care not to place excessive stress on leads. The followings explain main precautions.

- (1) Make spacing of the printed board device installation holes the same as that of the leads to avoid adding stress which may cause deforming leads during or after device insertion.
- (2) Avoid any assembly that causes stress between the device body and the leads after fixing the leads in the printed board. For example, it must be noted that if after the leads are soldered into the printed board a heat sink is installed on the device, excessive stress will accumulate in the leads due to installation position scattering of the heat sink, which invites solder crack, lead line pull out, package damage or others.
- (3) When using an automatic inserter, take care that shock is not added to the device body, especially during insertion. This prevents package or chip cracks due to shock forces.
- (4) When semiconductor devices are temporarily bonded with adhesive on the printed board, confirm if they are bonded adequately. Avoid using so much adhesive as to contact with electrodes.
- (5) When using taped products, be careful of jamming occurred by charged mounters. The cover tape and carrier tape peeling charge becomes higher the faster the peeling speed. To prevent being charged, avoid high-speed peeling and friction when possible. (Recommended peeling speed is under 10 mm/sec.)
- (6) Board installation by IC sockets sometimes occurs contact faults between the IC pins and IC socket, so avoid using IC sockets as much as possible.
- (7) For surface mount packages, the values for the junction section pattern of a printed board lead vary according to the solder paste materials used and the reflow conditions; however, they should be designed for 1.1 to 1.3 times the solder lead pin width.

6.4 Soldering

It is not desirable to subject semiconductor devices to high temperatures for a long period of time. For any methods such as solder iron or reflow, soldering must be done as quickly and at the lowest temperature as possible. The solder heat tolerance test standard of semiconductor device lead is 260°C for 10 seconds or 350 °C for 3 seconds at a distance of 1 to 1.5 mm from the device body. Be careful not to exceed these conditions when soldering. If highly acidic or alkaline flux is used in soldering, corrosion of the leads can occur, having negative effects on characteristics, so rosin type flux is recommended. Flux removal cleaning after soldering is important as flux can cause leakage in a high temperature and high humidity environment (see section 6.5 Cleaning methods).

For irons for correcting solder, use of either a grounded three-terminal iron or a grounded iron tip with a secondary voltage dropped by a transformer is considered adequate. In this case, be careful not to cause secondary fault due to grounded iron (Fig. 5).

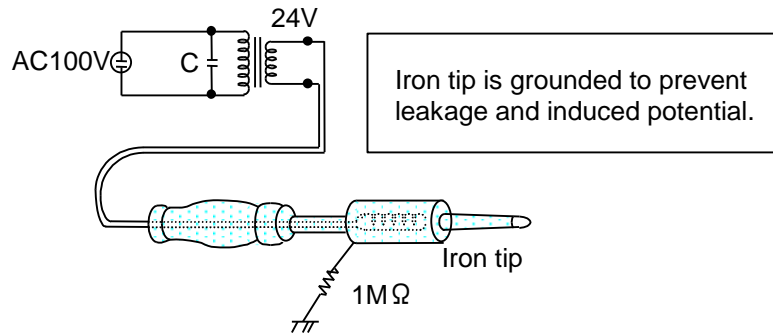

Fig. 5 Solder iron tip grounding

6.4.1 Pin insertion device (wave soldering bath / flowing solder bath)

In this method, the package lead pin soldering section is placed on the liquid surface of a flowing solder bath, but if the flowing solder touches the package body, package damage can result, so take care that the solder does not directly contact the package body. Fig. 6 shows the recommended conditions for flowing solder for lead-free products. Do not apply to lead-containing products.

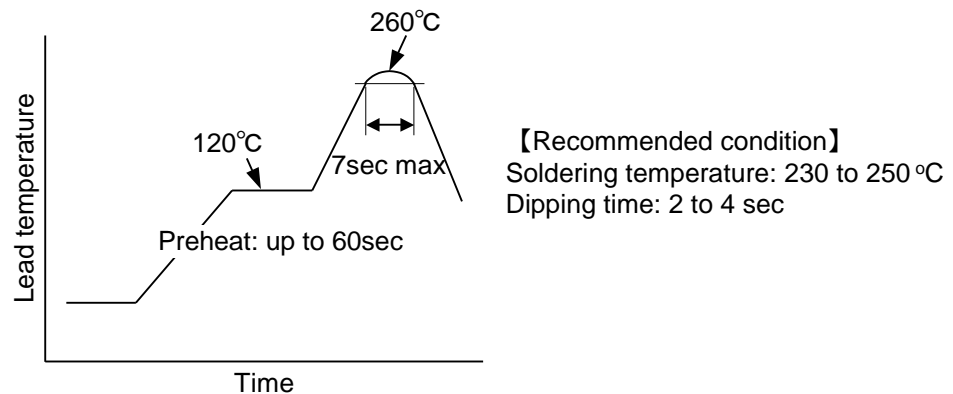

Fig. 6 Recommended conditions for flowing solder (lead-free products)

In wave solder bath use, the board can warp due to the temperature difference between the top surface and back side to which the solder heat is added. If soldering is done with the board in this warped condition, the board will try to return to its original shape when removed from the solder bath, and there is a chance of contact section cracks, or lead or package damage due to excessive stress. For this reason, clamp the board with a metal clasp so that warping does not occur during soldering when using wave solder baths (Fig. 7).

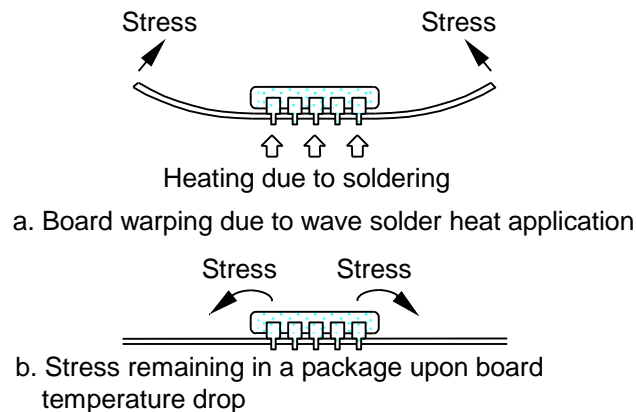

Fig. 7 Board warping in a wave solder bath

6.4.2 Surface mount devices (reflow bath)

The most-often used methods for surface mounting devices are the infrared reflow, vapor phase reflow methods. As the entire package is heated in these methods, significant heat stress is added to packages, and control of surface temperature is necessary. Care must be taken for peak temperature and time to keep package damage to a minimum. If peak temperature is high, package strength decreases and steam pressure within the package rises. Therefore, peak temperature must be as low as possible. As the steam pressure rises with time, treatment should be completed as quickly as possible. Fig. 8 shows the recommended conditions for surface mount reflow soldering for lead-free products. Do not apply to lead-containing products.

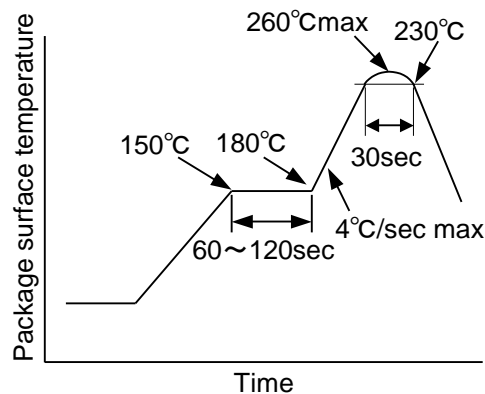

Fig. 8 Recommended conditions for reflow soldering (lead-free products)

6.5 Cleaning methods

Flux residue after soldering affects the reliability of components and board wiring, so cleaning is necessary as a rule. Cleaning methods include ultrasonic wave, soaking, spraying, and vapor cleaning. The features of each cleaning method are as follows:

- (1) Ultrasonic wave cleaning:
Ultrasonic wave cleaning vibrates a product in a solvent to clean it, which is good for cleaning microscopic gaps, but care is necessary to avoid possible damage to the contact between the board and the device.
- (2) Soaking:
A product can be soaked in a warm or cold cleaning solution. The cleaning solution must be very pure.
- (3) Spray cleaning:
A solvent under high pressure is sprayed onto a product. High purity of the solvent is necessary.
- (4) Vapor cleaning:
Solvent stream is used to clean. Since cleaning is possible with solvents containing no impurities, vapor cleaning is most often used in final cleaning processes.

Cleaning is generally carried out combining these processes. A general cleaning process is shown in Fig. 9.

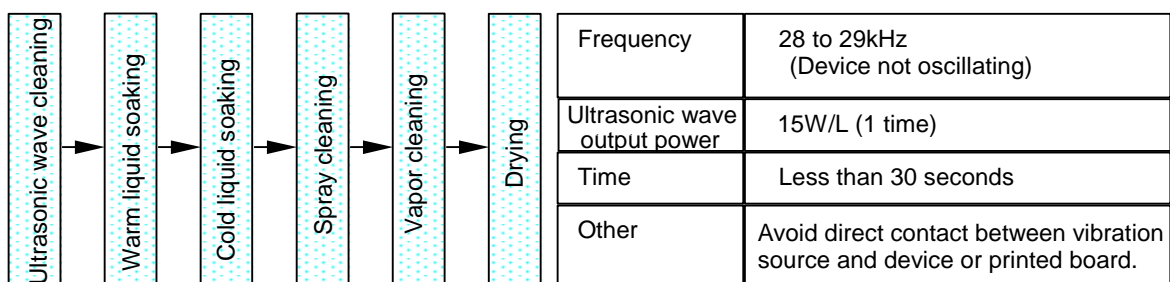

Fig. 9 General cleaning process

Be attentive to the following points during cleaning:

- (a) For ultrasonic wave cleaning, to prevent destruction, care is necessary to prevent device oscillation. Care is also necessary with the applied frequency, power (especially peak power), and time:
Connecting wires can oscillate and break when ultrasonic cleaning is carried out, especially for ceramic package families such as QFN (LCC) and QFP (ceramic), which are cavity packages.
- (b) Since markings will sometimes disappear after cleaning, apply after confirmation in actual use conditions.
- (c) Consideration of public environmental and safety standards is necessary when solvents are used.

6.6 Mounting on heat sinks

Heat sinks are generally used with power devices to lower the junction temperature by radiating heat externally. The following precautions are necessary when using heat sinks attached to semiconductor devices for preventing loss of reliability.

- (1) It is often the case that the potential of a heat release part is the same as that of device ground. Therefore, be careful to prevent electrical noise and surge from entering through heat sinks.
- (2) Silicone grease selection:
A thin layer of silicon grease is generally applied evenly over the contact surface between the device and the heat sink to maximize heat conduction. However, some resin-molded devices will absorb the silicon grease and become swollen. Avoid high-viscosity or non-homogeneous greases because forces that develop as the package is tightened to the heat sink may cause package cracking. Avoid application of excessive amounts of grease for the same reason.
- (3) Tightening torque:
Insufficient tightening torque invites an increase in heat resistance, and excessive torque invites such failures as warping of the device, die destruction, and connector lead breakage. Please use the tightening torque value 0.39 to $0.59\text{N}\cdot\text{m}$ (4 to $6\text{ kg}\cdot\text{cm}$).
- (4) Heat sink flatness:
When attaching devices to heat sinks, inappropriate heat sinks will hinder heat radiation. In addition, adding unnecessary stress will cause characteristic degradation or resin cracks. Observe the following points regarding heat sinks:
 - (a) To avoid a heat sink causing convex or concave warping, keep the warp between screw holes less than 0.05 mm (Fig. 10). Also, twist to a maximum of 0.05 mm .
 - (b) For aluminum, copper, and iron boards, make sure there is no press tension, and always bevel the screw holes.
 - (c) A contact surface with a device must be ground flat ($\nabla\nabla$ finishing).
 - (d) Prevent and remove any shaved particles between the IC header and the heat sink.
 - (e) Make sure the screw hole gaps match those of the device. If they are too wide or too narrow, resin cracks can result.

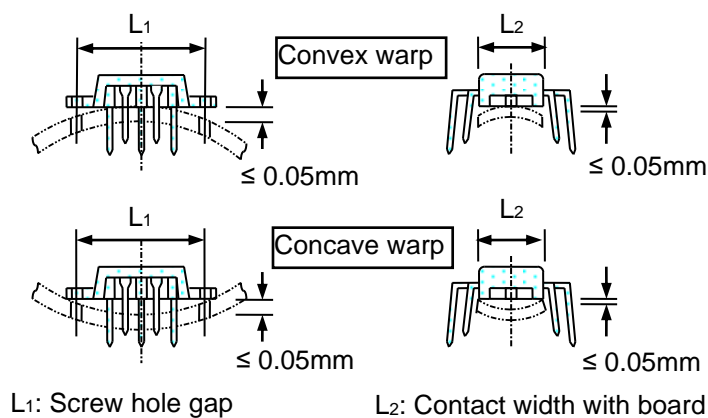

Fig. 10 Heat sink warping:

- (5) Avoid direct soldering on the device heat sink side:
Direct soldering on the device heat sink side can cause destruction or a shorter life span by adding heat in excess of the junction temperature guarantee value.
- (6) Avoid adding mechanical stress to packages:
When metal tools (drivers or jigs) are used to tighten heat sink part of a plastic package, pay attention to avoid hitting plastic part by the tools, that may cause packages cracks in packages, internal mechanical stress, speeding of device contact section fatigue, and destruction or broken connection faults. Therefore, sufficient caution is required.
- (7) Avoid processing or transforming the tab or package:
If cutting, forming, or processing is done to the device, an increase in thermal resistance is encouraged and abnormal stress is applied inside the device, which promotes failures.
- (8) Note which screws are to be used:
The screws that attach the heat sink to the device are generally classified into small screws and tapping screws. Observe the following precautions when using these types of screws:
- Use small bind and truss screws that have heads which meet JIS-B1101 standards.
 - Avoid using countersink screws, which add abnormal stress to devices (Fig. 11).
 - Even when using tapping screws, ensure the tightening torque noted previously.
 - Use tapping screws that are thinner than the device attachment hole diameter. If thicker screws are used, tapping the device attachment holes or heat sinks can promote failures.

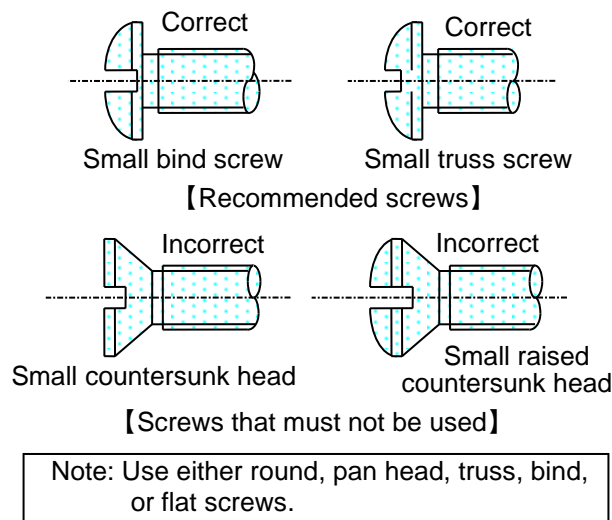

Fig. 11 Recommended and Prohibited Screws

- (9) Heat sink screw hole diameters:
Note the following points.
- Do not make the heat sink hole diameter or beveling larger than the head diameter of the screw. The tightening torque will deform copper boards and plastic packages, especially for devices using copper boards as flange material.
 - When using tapping screws, the tightening torque becomes large and the recommended torque is exceeded, or the desired contact resistance becomes unobtainable.
- (10) Other precautions:
- When attaching one heat sink to two or more devices, the heat resistance of each device rises.
 - Heat sinks must have an appropriate shape and size. Use forced cooling as necessary.
- How to obtain junction temperature:
- Measure the case temperature.
 - Calculate the junction temperature using heat resistance shown in datasheet.
- $$(T_j = R_{j-c} \times P + T_c)$$

7. Packaging / storing

7.1 Packaging precautions

There are many factors in device destruction (electrostatic or mechanical destruction) related to user handling. First, cautions concerning storage and packing for semiconductor devices are listed below.

(1) Semiconductor device storing

- (a) Semiconductor devices are generally in dedicated storage cases such as magazines and trays before shipping. Use those dedicated storage cases whenever possible.
- (b) When the dedicated storage cases cannot be used, store in cases that:
 - Do not cause chemical reactions or generate harmful gases
 - Are constructed to prevent device destruction due to vibration or shock
 - Have case parts that contact the device pins made of conductive or non-charging material (surface painted with a charge preventing agent)
- (c) When handling devices susceptible to electrostatic destruction such as high frequency or MOS devices, use anti-static finger sheathes or gloves after discharging static electricity from the worker and clothing through a high resistance (about $1\text{M}\Omega$) to ground.

(2) Packaging:

Semiconductor devices contained in storage cases must be packaged to avoid external influences such as shock, rain, or contamination.

- (a) Keep impact to a minimum. Consider the mechanical strength and moisture resistivity of the storage and the shipping method.
- (b) Indicators such as those in Fig. 12 must be put on the external cardboard box as necessary. Avoid overloading of the external boxes because there is a possibility of damage or fall.
- (c) When semiconductor devices are transported for a long period such as in sea shipping, use vacuum packing or hermetic containers for relatively bad environments,
- (d) Do not reuse magazines whose surfaces are treated for charge prevention.



Fig. 12 External indicators

7.2 Storage methods for semiconductor devices

Store semiconductor devices in environments controlled temperature and humidity and with no ultraviolet rays, harmful gases such as hydrogen sulfide, radiation such as x-rays, static electricity, and strong electromagnetic fields (Fig. 13).

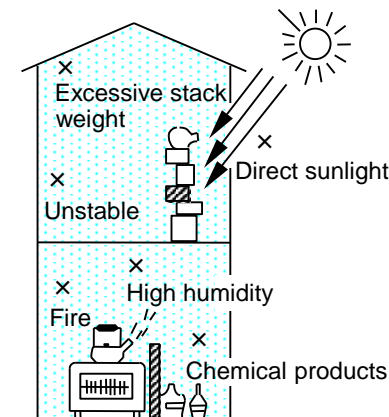

Fig. 13 Bad storage locations

(1) Storage environment:

(a) Temperature / humidity range

Normal values of temperature and humidity are desirable in a semiconductor device storage location; avoid extremes. Temperatures of 5 to 35°C and 45 to 75% relative humidity are desirable condition. (For restrictions on storage, comply with the specified conditions.)

(b) Cleanliness

Avoid places that are dusty or where corrosive gases, such as garage, are generated.

(c) Stable temperature

Store semiconductor devices in environments where there are hardly any sudden temperature changes, since moisture condensation can occur in devices. Choose darker places with no direct sunlight or strong lighting.

(d) Other

Choose a location free from radiation, static electricity, and strong electromagnetic fields.

(2) Storage form:

(a) For storage form, store semiconductor devices under the conditions described in section 7.1.

(b) Take care so that weight is not applied to semiconductor devices in storage. Weight can be applied unexpectedly, especially in stacking. Avoid placing heavy objects on devices.

(c) Store semiconductor device external terminals in an unprocessed condition. Leads tarnished and attached foreign matter during storage may cause solderability failure.

(d) For taped products, avoid leaving them in mounters. When left in mounters, cover tapes can be peeled off due to tape distortion.

(3) Long-term storage:

When storing semiconductor devices for long periods (one year or more), there is a chance of lead pin solderability deterioration, rusting, or electrical characteristic faults; the precautions below are especially necessary.

(a) See storage environment above, 7.2 (1), for proper storage conditions.

(b) When long-term storage (one year or more) is foreseen, use vacuum packing or hermetic containers with silica gel placed inside.

(c) When an unexpectedly long period has elapsed (one to eight years) in normal storage, inspection for solderability and appearance, such as lead rusting, before use is necessary.

(d) When left in very bad environments or when more than one year has elapsed in normal storage, inspect solderability, lead rusting, and electrical characteristics. (See section 6.2 for moisture absorption countermeasure for surface mount packages.)

(4) Chip and wafer storage:

Semiconductor chips and wafers require stricter storage than packaged products. Fig. 14 shows an example chip storage container. Avoid leaving or storing chips or wafers directly exposed to air.

Blow-up of chip tray section

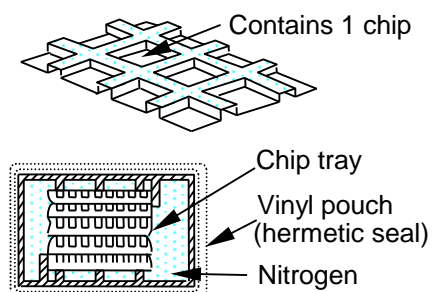

Fig. 14 Chip storage containers

- (a) Store chips and wafers in a proper container and do not open or close more than necessary. Normal storage containers have a hermetic construction and protect chips and wafers from temperature, humidity, harmful gases, and from vibration and shock during shipment or movement.
- (b) Avoid leaving containers open.
- (c) Store in an environment of 5 to 30°C, 45 to 75% RH, away from the effects of volatile chemicals.
- (d) When taking chips and wafers from or placing them into storage containers, handle gently with vacuum tweezers or collets to avoid scratching surfaces of chips and wafers.
- (e) After storage, five days is the standard maximum time from opening a chip or wafer container until assembly. However, during periods between work such as nights, devices must be placed in dry nitrogen. After package opening, keep in dry nitrogen (lower than the -30°C dew point) up to 20 days; for packages in an unopened condition, keep less than 3 months.

7.3 Precautions in moving and transporting

When shipping semiconductor devices or printed boards installed them, heed the precautions common to other electronic components. Be careful about the following:

- (1) Handle the external cardboard box gently. Especially, shocks such as dropping can cause device destruction.
- (2) Handle the internal box especially gently. If dropped, products may be thrown out from magazines or trays, causing leads to be bent or damaged.
- (3) Keep the package dry. Especially, be careful to prevent it from getting wet during shipment in rain or snow.
- (4) Ship in containers and jigs that do not produce static electricity or charging due to vibration during shipping. Use of anti-static containers or boxes is effective.
- (5) Prevent electrostatic destruction from workers or clothing by grounding through a large resistance during handling.
- (6) Move printed boards with semiconductor devices installed using methods that prevent static electricity charging, and short pins. Also, keep mechanical vibration and shock to the absolute minimum when shipping semiconductor devices or printed boards.