

3-phase IGBT/MOS Gate Driver IC

ECN30502S Product Specification

Rev. 2

1. Product Description

1.1 Features

- (1) PWM control of top and bottom arms is possible with six control signals
- (2) Maximum Ratings: 620V, suitable for the system from 200VAC to 240VAC
- (3) Drives a motor using a high voltage DC power supply and a low voltage DC power supply (15V)

1.2 Functions

- (1) Fault function (Over-current protection, Vcc low-voltage detection)
- (2) Built-in bootstrap diode
- (3) 5V power supply circuit
- (4) Over-current protection (detects at 0.5V)
- (5) Vcc low-voltage detection
- (6) Top arm low-voltage detection

1.3 Block Diagram of IC

FIGURE 1.3.1 shows block diagram.

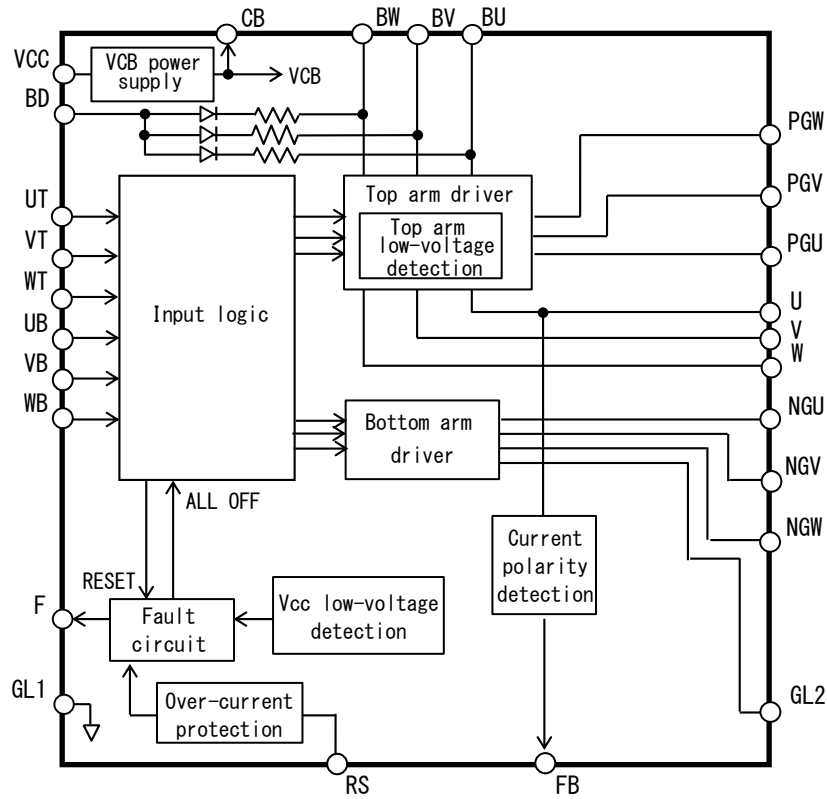
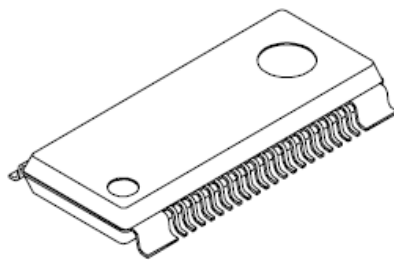

FIGURE 1.3.1 Block Diagram of IC

1.4 Package



(Package: HSOP-36AN)

FIGURE 1.4.1 Package of ECN30502S

2. Specification

2.1 Maximum Ratings

TABLE 2.1.1 Maximum Ratings

Condition: Ta=25°C

No.	Item	Symbol	Pin	Rating	Unit	Remarks
1	High voltage device withstand voltage	VBV	BU,BV,BW	620	V	
2	GL2 pin voltage	VGL2	GL2	-5 to VCC	V	
3	U, V, W pin voltage	VU,VV,VW	U,V,W	-5 to 600	V	
4	Voltage between BU-BD, BV-BD, BW-BD	VBUD VBVD VBWD	BU,BV,BW, BD	-5 to 600	V	
5	Vcc power supply voltage	VCC	VCC,BD	20	V	
6	Voltage between BU-U, BV-V, BW-W	VBSU VBSV VBSW	BU,U BV,V BW,W	20	V	
7	Voltage between VCC-GL2	VCCGL2	VCC,GL2	23	V	$-5V \leq VGL2 \leq -3V$
8	Input voltage	VIN	UT,VT,WT UB,VB,WB, RS	-0.5 to VCB+0.5	V	
9	Fault output voltage	Vflt	F	-0.5 to VCB+0.5	V	
10	FB output voltage	VFB	FB	-0.5 to VCB+0.5	V	
11	VCB supply output current	ICBMAX	CB	50	mA	
12	Junction operating temperature	Tjop	—	-40 to +125	°C	Note 1
13	Storage temperature	Tstg	—	-40 to +150	°C	

Note 1: Thermal resistance

Between junction and case : Rjc = 3°C/W (Reference value)

2.2 Electrical Characteristics

TABLE 2.2.1 Electrical Characteristics (1/2) Suffix (T: Top arm, B: Bottom arm) Condition: Ta=25°C

No.	Item		Symbol	Pin	Min.	Typ.	Max.	Unit	Condition
1	Standby current		Is1	VCC	—	3	10	mA	VCC=15V, GL2=0V UT,VT,WT,UB,VB,WB=0V ICB=0A
			Is2	BU, BV, BW	—	15	30	µA	Between BU-U,BV-V,BW-W =15V
2	Output source current		Io+	PGU, PGV, PGW NGU, NGV, NGW	0.20	0.25	—	A	VCC=15V, Pulse width ≤ 10µs Between BU-PGU,BV-PGV, BW-PGW=15V Between VCC-NGU,NGV, NGW=15V
3	Output sink current		Io-	PGU, PGV, PGW NGU, NGV, NGW	0.30	0.40	—	A	VCC=15V, Pulse width ≤ 10µs Between PGU-U,PGV-V, PGW-W=15V Between NGU,NGV, NGW-GL2=15V
4	High level output voltage		VOH	PGU, PGV, PGW NGU, NGV, NGW	—	—	100	mV	VCC=15V, Io+=0A Between BU-PGU,BV-PGV, BW-PGW Between VCC-NGU,NGV, NGW
5	Low level output voltage		VOL	PGU, PGV, PGW NGU, NGV, NGW	—	—	100	mV	VCC=15V, Io-=0A Between PGU-U,PGV-V, PGW-W Between NGU,NGV, NGW-GL2
6	Output delay time	Turn ON	TdONT	PGU, PGV, PGW	—	0.4	1.0	µs	VCC=15V, When connecting following capacitance: Between PGU-U,PGV-V, PGW-W=1000pF Between NGU,NGV,NGW- GL2=1000pF
7			TdONB	NGU, NGV, NGW	—	0.4	1.0	µs	
8		Turn OFF	TdOFFT	PGU, PGV, PGW	—	0.4	1.0	µs	
9			TdOFFB	NGU, NGV, NGW	—	0.4	1.0	µs	
10	Leakage current at high voltage pin		IL	BU, BV, BW U, V, W	—	—	10	µA	BU,BV,BW=U,V,W=450V

TABLE 2.2.1 Electrical Characteristics (2/2) Suffix (T: Top arm, B: Bottom arm) Condition: Ta=25°C

No.	Item	Symbol	Pin	Min.	Typ.	Max.	Unit	Condition	
11	Over-current protection	Reference voltage	Vref	RS, F	0.45	0.50	0.55	V	VCC=15V
12		Delay time	Tref		—	2.0	4.0	µs	
13	UT, VT, WT, UB, VB, WB inputs	Voltage	VIH	UT, VT, WT	2.5	—	—	V	VCC=15V
14			VIL	UB, VB, WB	—	—	1.0	V	
15		Current	IIL		-10	—	—	µA	Input=0V, VCC=15V
16	IIH			—	—	100	µA	Input=4.5V, VCC=15V	
17	RS input current		IILRS	RS	-100	—	—	µA	VCC=15V, RS=0V Note 2
18	VCB supply output	Voltage	VCB	CB	4.5	5.0	5.5	V	VCC=15V, ICB=0A
19		Current	ICB	CB	—	—	45	mA	
20	Vcc low-voltage detection	Operating voltage	LVSDON	VCC, F PGU, PGV, PGW	9.5	11.0	12.5	V	
21		Recovery voltage	LVSDOFF	PGW NGU, NGV, NGW	10.0	11.5	13.0	V	
22	Top arm low-voltage detection	Operating voltage	LVSDONT	BU, BV, BW PGU, PGV, PGW	9.0	10.0	11.0	V	
23		Recovery voltage	LVSDOFFT	PGW	9.5	10.5	11.5	V	
24	F, FB output resistance		RON	F, FB	—	0.4	0.8	kΩ	IF, IFB=-1mA, VCC=15V Note 3
25	Fault reset delay time		tflrs	F	—	15	30	µs	VCC=15V
26	Bootstrap diode forward voltage		VFDB	BU, BV, BW BD	—	1.0	1.5	V	I=1mA, Between BD-BU,BV,BW Included series resistance

Note 1: Internal pull-down resistor is typically 200kΩ. The equivalent circuit is shown in FIGURE 2.2.1.

Note 2: Internal pull-up resistor is typically 260kΩ. The equivalent circuit is shown in FIGURE 2.2.2.

Note 3: The equivalent circuit is shown in FIGURE 2.2.3.

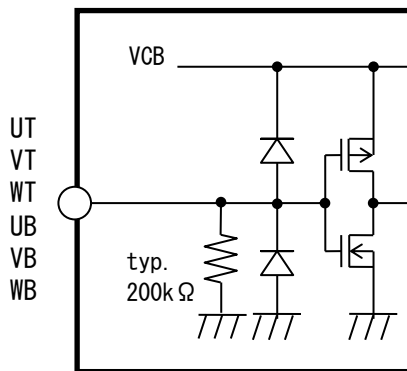

FIGURE 2.2.1 Equivalent Circuit Around UT, VT, WT, UB, VB, WB Pins

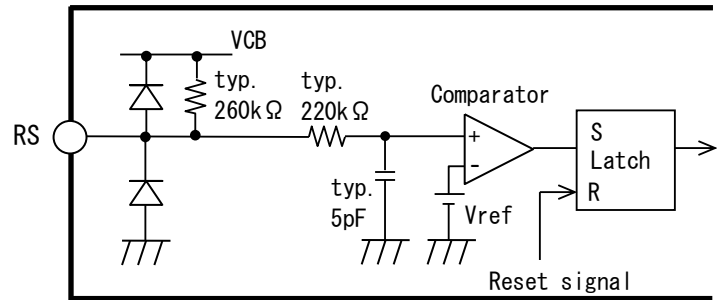

FIGURE 2.2.2 Equivalent Circuit Around RS Pin

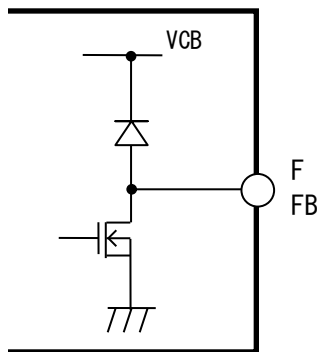

FIGURE 2.2.3 Equivalent Circuit Around F, FB Pins

2.3 Operating Condition

TABLE 2.3.1 Operating Condition

Condition: Ta=25°C

No.	Item	Symbol	Pin	Min.	Typ.	Max.	Unit	Remarks
1	U, V, W pin voltage	VUop VVop VWop	U V W	-3	-	450	V	VCC=15V Each voltage between BU-U, BV-V, BW-W:15V
2	Supply voltage	VCCop	VCC, BD	13.5	15.0	16.5	V	
3	Voltage between BU-U, BV-V, BW-W	VBSUop VBSVop VBSWop	BU, U BV, V BW, W	11.0	15.0	16.5	V	Note 1

Note 1: During power supply startup, when the voltage is equal to or lower than the recovery voltage of the top arm low-voltage detection, the IC may not operate.

2.4 Functions and Operations

2.4.1 Truth Table

TABLE 2.4.1.1 Truth Table

Input UT, VT, WT UB, VB, WB	Output PGU, PGV, PGW NGU, NGV, NGW
L	L
H Note 1	H

Note 1: When the top input and bottom input in the same phase are "H" simultaneously, the top and bottom arm outputs in this phase are both "L".

2.4.2 Definition of Output Delay Time

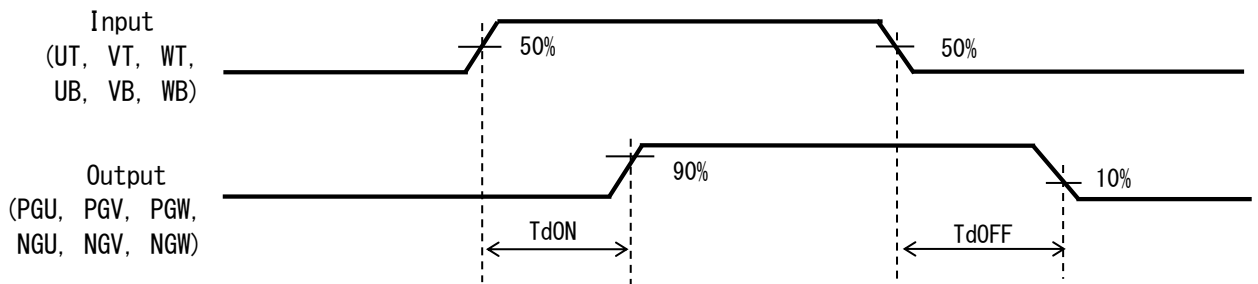

FIGURE 2.4.2.1 Definition of Output Delay Time (Capacitive Load)

2.4.3 Over-current Protection

When the voltage at the RS pin reaches the over-current protection reference voltage (V_{ref} , typ. 0.50V), the F output is "L", and all outputs (top and bottom arms) become "L". When the voltage at the RS pin drops below the over-current protection reference voltage (V_{ref} , typ. 0.50V) and the 6 input signals (UT, VT, WT, UB, VB, WB) are all held at "L" level for the Fault reset delay time (t_{flrs}) or longer, the F output is "H" and the IC returns to a state in which the output is H or L depending on input signals.

Just after the V_{cc} power supply is turned on, the over current protection may operate. In this case, reset the "All outputs L" state in the same way as above.

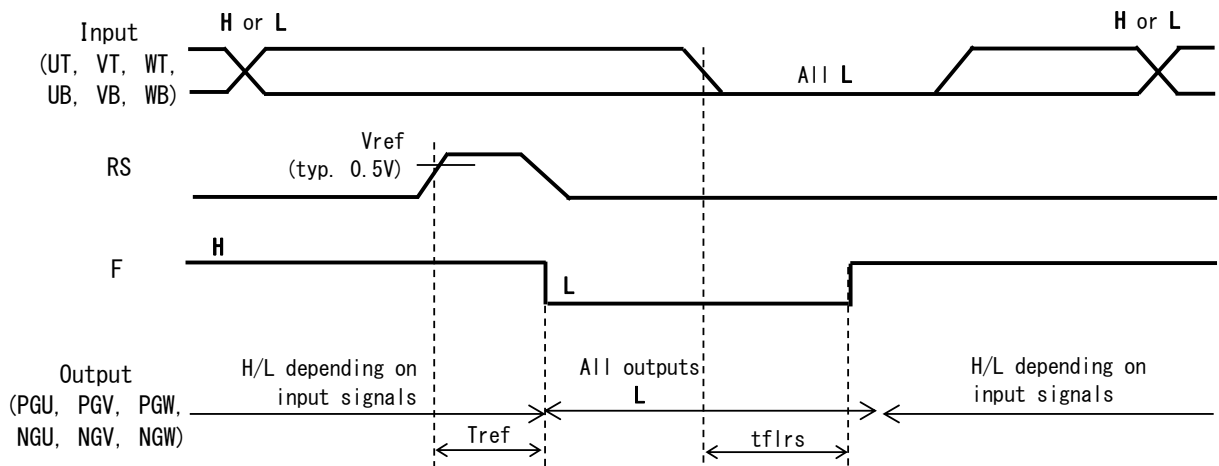

FIGURE 2.4.3.1 Timing Chart for Over-current Protection Operation

2.4.4 Vcc Low-voltage Detection

When the Vcc voltage drops below the operating voltage of the Vcc low-voltage detection (LVSDON, typ. 11.0V), the F output is “L”, and all outputs (top and bottom arms) become “L”. When the Vcc voltage goes up above the recovery voltage of the Vcc low-voltage detection (LVSDOFF, typ. 11.5V) and the 6 input signals (UT, VT, WT, UB, VB, WB) are all held at “L” level for the Fault reset delay time (tflrs) or longer, the F output is “H” and the IC returns to a state in which the output is H or L depending on input signals.

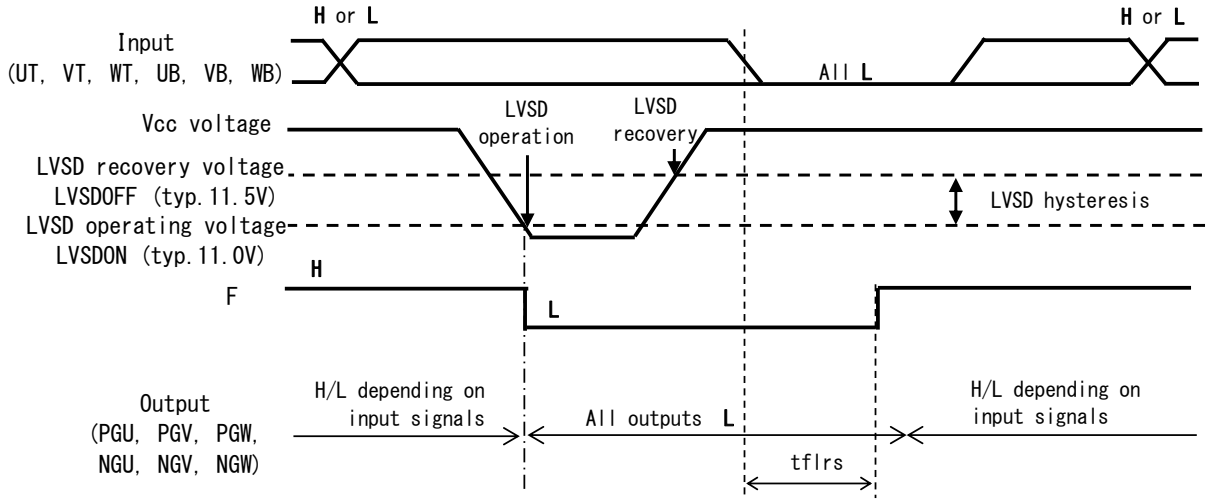

FIGURE 2.4.4.1 Timing Chart for Vcc Low-voltage Detection Operation (LVSD Operation)

2.4.5 Top Arm Low-voltage Detection

When the top arm power supply voltages (voltages between BU and U, BV and V, BW and W) drop below the operating voltage of the top arm low-voltage detection (LVSDONT, typ. 10.0V), the top arm output of the corresponding phase becomes “L” even when the top arm input signals are “H”. This “L” output state is reset when the “H” signal is inputted to the top arm after the top arm power supply voltages (voltages between BU and U, BV and V, BW and W) goes up above the recovery voltage of the top arm low-voltage detection (LVSDOFFT, typ. 10.5V). However, even when the “L” output state is reset in a state in which the top arm input signal is “H”, the top arm does not become “H”. By inputting the “L” signal and then inputting the “H” signal again, the top arm becomes “H”. The Fault signal is not outputted in this function operation.

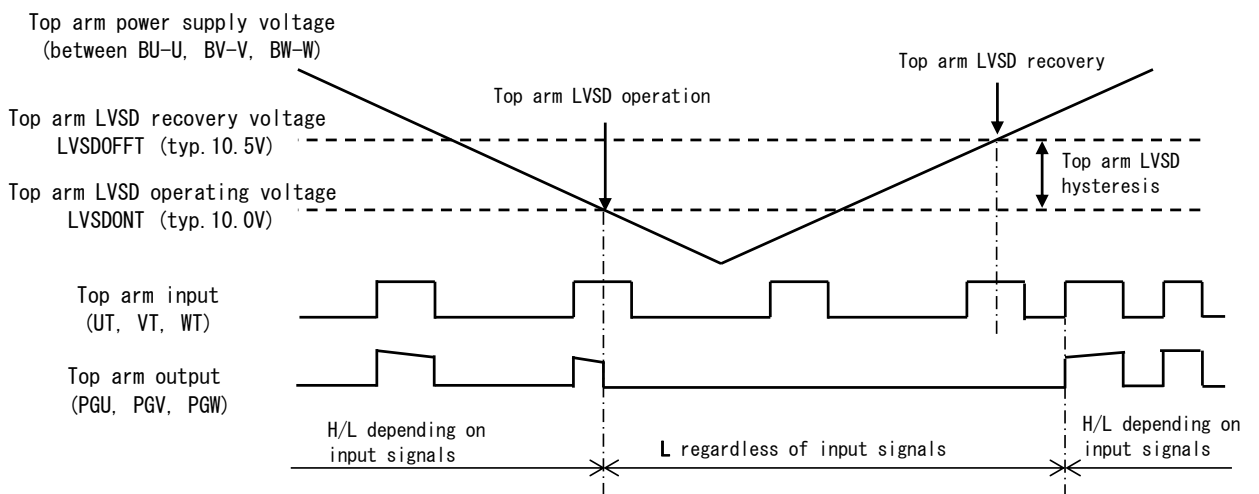

FIGURE 2.4.5.1 Timing Chart for Top Arm Low-voltage Detection Operation (Top arm LVSD Operation)

3. Standard Applications

3.1 External Components

TABLE 3.1.1 External Components

Component	Standard value	Usage	Remarks
CO	1.0μF ±20%, 25V	Smooths the internal power supply (VCB)	
CV1	Note 1	Smooths the Vcc power supply	
CV2	Note 1	Smooths the Vs power supply	
Cb	1.0μF ±20%, 50V	For bootstrap	Note 2
Rs	Note 3	Sets over-current protection	
CF	Note 1	Eliminates output noise of Fault signal	
RF	10kΩ ±5%	For pull up	

Note 1: Regarding the capacitor, select peripheral components suitable for your system specifications and conditions of use, considering redundancy in design.

Note 2: The capacitance value of the bootstrap capacitor depends on the operating conditions. Set the capacitance value taking into account the DC bias characteristics.

Note 3: The over-current protection set value (IO) can be calculated as follows.

$$IO = Vref / Rs \text{ (A)}$$

Vref: Over current protection reference voltage

Rs: Shunt resistance value

In setting current values, delay time to turn the output power device off and variability of Vref and Rs need to be considered. In practice, check the coil current of the motor. Set the shunt resistance so that voltage of the GL2 pin is within the specified voltage range of GL2 pin (VGL2) shown in TABLE 2.1.1.

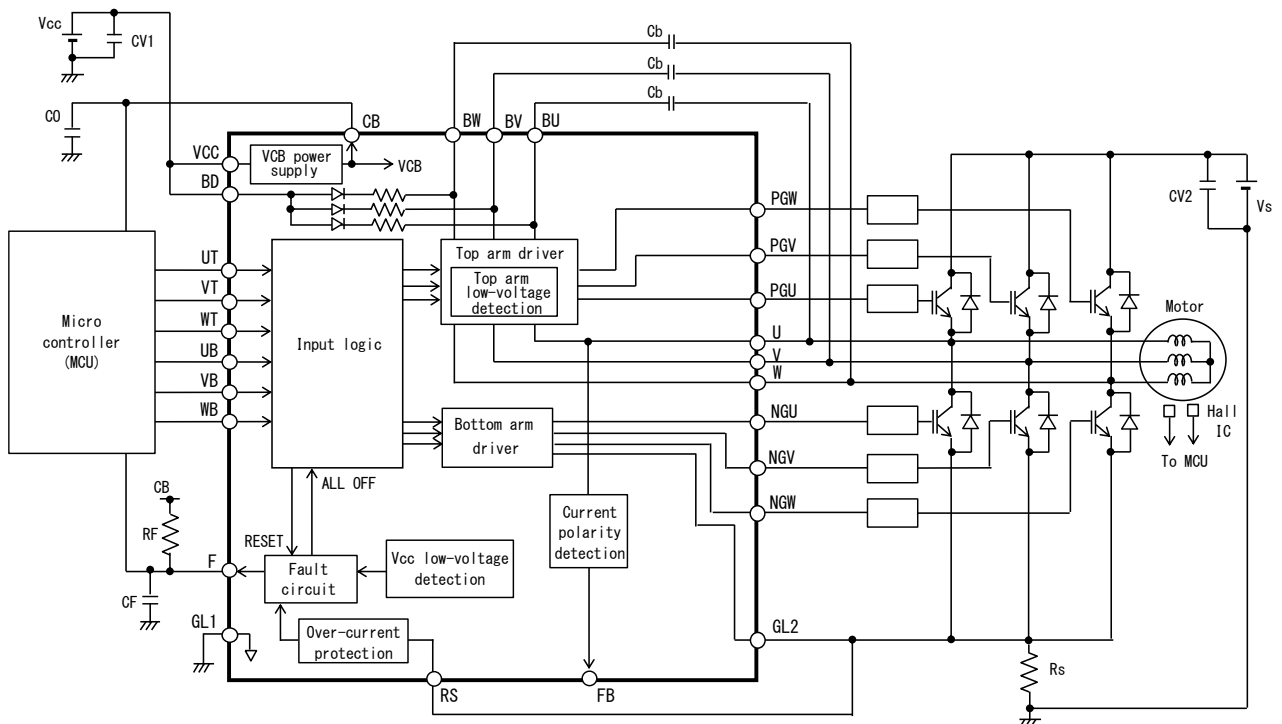

FIGURE 3.1.1 Block Diagram and External Components of IC

3.2 Input Pins (UT, VT, WT, UB, VB, WB)

In some applications, input pins may be sensitive to noise due to high impedance. If noise is detected at an input pin, the following resistor and/or capacitor should be added.

- Resistor : 5.6kΩ ±5% pull-down resistor between the GL1 pin and input pins
- Capacitor : 470pF ±20% ceramic capacitor close to the input pins

4. Pin Locations

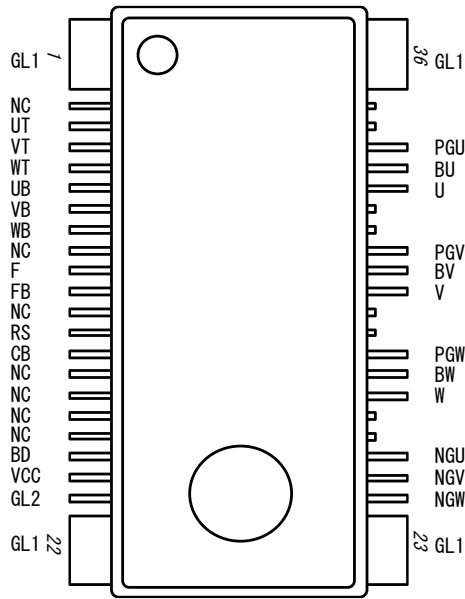

FIGURE 4.1 Pin Locations (Top view)

5. Pin Assignments

TABLE 5.1 Pin Assignments

Pin No.	Symbol	Pin functions	Remarks
2,9,12,15,16,17,18	NC	No connection	Note 1
1,22,23,36	GL1	Control system GND	
3	UT	Input control signal for U-phase top arm	
4	VT	Input control signal for V-phase top arm	
5	WT	Input control signal for W-phase top arm	
6	UB	Input control signal for U-phase bottom arm	
7	VB	Input control signal for V-phase bottom arm	
8	WB	Input control signal for W-phase bottom arm	
10	F	Fault signal output	
11	FB	Feedback signal (motor current polarity signal) output	Note 2
13	RS	Input for over-current protection	
14	CB	VCB power supply output	
19	BD	For bootstrap diode	
20	VCC	Control power supply	
21	GL2	Reference pin of bottom arm outputs (connected to a current detection resistor)	
24	NGW	W-phase bottom arm gate drive signal output	
25	NGV	V-phase bottom arm gate drive signal output	
26	NGU	U-phase bottom arm gate drive signal output	
27	W	Reference pin of W-phase top arm output	Note 3
28	BW	W-phase top arm drive circuit power supply	Note 3
29	PGW	W-phase top arm gate drive signal output	Note 3
30	V	Reference pin of V-phase top arm output	Note 3
31	BV	V-phase top arm drive circuit power supply	Note 3
32	PGV	V-phase top arm gate drive signal output	Note 3
33	U	Reference pin of U-phase top arm output	Note 3
34	BU	U-phase top arm drive circuit power supply	Note 3
35	PGU	U-phase top arm gate drive signal output	Note 3

Note 1: Not connected to the chip in the IC.

Note 2: Used when controlling the motor using our software.

Note 3: High voltage pin.

6. Inspection

Hundred percent inspections shall be conducted on electric characteristics at room temperature.

7. Precautions for Use

7.1 Countermeasures against Electrostatic Discharge (ESD)

- (a) Customers need to take precautions to protect ICs from electrostatic discharge (ESD). The material of the container or any other device used to carry ICs should be free from ESD, which can be caused by vibration during transportation. Use of electrically conductive containers is recommended as an effective countermeasure.
- (b) Everything that touches ICs, such as the work platform, machine, measuring equipment, and test equipment, should be grounded.
- (c) Workers should be high-impedance grounded (100kΩ to 1MΩ) while working with ICs, to avoid damaging the ICs by ESD.
- (d) Friction with other materials, such as high polymers, should be avoided.
- (e) When carrying a PCB with a mounted IC, ensure that the electric potential is maintained at a constant level using the short-circuit terminals and that there is no vibration or friction.
- (f) The humidity at an assembly line where ICs are mounted on circuit boards should be kept around 45 to 75 percent using humidifiers or such. If the humidity cannot be controlled effectively, using ionized air blowers (ionizers) is effective.

7.2 Maximum Ratings

Regardless of changes in external conditions during use of our IC, the “maximum ratings” described in this document should never be exceeded when designing electronic circuits that employ our IC. If maximum ratings are exceeded, our IC may be damaged or destroyed. In no event shall our company be liable for any failure in our IC or any secondary damage resulting from use at a value exceeding the maximum ratings.

7.3 Derating Design

Continuous high-load operation (high temperatures, high voltages, large currents) should be avoided and derating design should be applied, even within the ranges of the maximum ratings, to ensure reliability.

7.4 Safe Design

Our IC may fail due to accidents or unexpected surge voltages. Accordingly, adopt safe design features, such as redundancy and measures to prevent misuse, in order to avoid extensive damage in the event of a failure.

7.5 Application

If our IC is applied to the following uses where high reliability is required, obtain the document of permission from our company in advance.

- Automobile, Train, Vessel, etc.

Do not apply our IC to the following uses where extremely high reliability is required.

- Nuclear power control system, Aerospace instrument, Life-support-related medical equipment, etc.

7.6 Soldering

(1) Soldering Condition

The recommended reflow soldering condition is shown in FIGURE 7.6.1.

High stress by mounting, such as long time thermal stress by preheating, mechanical stress, etc., can lead to degradation or destruction. Make sure that your mounting method does not cause problem as a system.

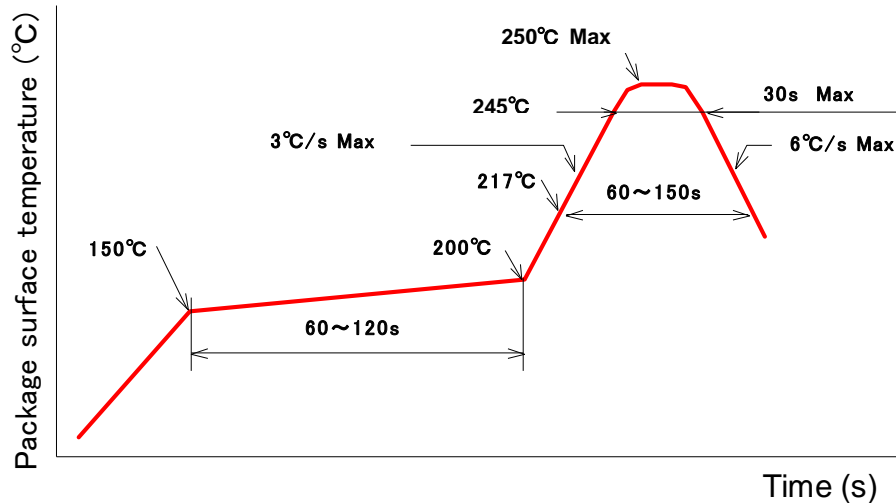

FIGURE 7.6.1 Recommended Conditions for Infrared Reflow or Air Reflow

(2) Reliability of Solder Connection

The reliability of solder connection depends on soldering condition, materials of circuit boards, footprint, etc. Test it sufficiently by heat cycle test, heat shock test, and so on after mounting ICs on circuit boards.

7.7 Storage Conditions

(1) Before opening the moisture prevention bag (aluminum laminate bag)

- Temperature: less than 40°C
- Humidity: less than 90%RH
- Period: less than 12 months

(2) After opening the moisture prevention bag (aluminum laminate bag)

- Temperature: 5°C to 30°C
- Humidity: less than 60%RH
- Period: less than 168 hours

※ When the period of (1) and (2) is likely to expire, store the IC in a drying furnace (10%RH or lower) at ordinary temperature.

(3) Baking process

When the period of (1) and (2) has expired, the IC should be baked in accordance with the following conditions. (However, when the IC is stored in a drying furnace (10%RH or lower) at ordinary temperature, there is no need to bake.) Do not bake the tape and the reel of the taping package because they are not heat resistant. Transfer the IC to a heat resistant container prior to baking.

- Temperature: 125°C to 135°C
- Period: more than 48 hours

7.8 Others

See “Instructions for Use of High-Voltage Monolithic ICs” and “Application Note” for other precautions and instructions on how to deal with these kinds of products.

8. Usage

- (1) Our company warrants that our products have the specified performance according to the respective specifications at the time of its sale. Testing and other quality control techniques of our products by our company are utilized to the extent we need to meet the specifications described in this document. Not every device of our products is specifically tested on all parameters, except those mandated by relevant laws and/or regulations.
- (2) Following any claim regarding the failure of a product to meet the performance described in this document made within one month of product delivery, all the products in relevant lot(s) shall be re-tested and re-delivered. Our products delivered more than one month before such a claim shall not be counted for such response.
- (3) Our company assumes no obligation nor makes any promise of compensation for any fault which should be found in a customer's goods incorporating the products in the market. If a product failure occurs for reasons obviously attributable to our company and a claim is made within six months of product delivery, our company shall offer free replacement or payment of compensation. The maximum compensation shall be the amount paid for the products, and our company shall not assume responsibility for any other compensation.
- (4) Our company reserves the right to make changes in this document and to discontinue mass production of the relevant products without notice. Customers are advised to confirm specification of the product of inquiry before purchasing of the products that the customer desired. Customers are further advised to confirm before purchasing of such above products that the product of inquiry is the latest version and that the relevant product is in mass production status if the purchasing of the products by the customer is suspended for one year or more.
- (5) When you dispose of our products and/or packing materials, comply with the laws and regulations of each country and/or local government. Conduct careful preliminary studies about environmental laws applying to your products such as RoHS, REACH. Our company shall not assume responsibility for compensation due to contravention of laws and/or regulations.
- (6) Our company shall not be held liable in any way for damages and infringement of patent rights, copyright or other intellectual property rights arising from or related to the use of the information, products, and circuits in this document.
- (7) No license is granted by this document of any patents, copyright or other intellectual property rights of any third party or of our company.
- (8) This document may not be reprinted, reproduced or duplicated, in any form, in whole or in part without the express written permission of our company.
- (9) You shall not use our products (technologies) described in this document and any other products (technologies) manufactured or developed by using them (hereinafter called "END Products") or supply our products (technologies) and END Products for the purpose of disturbing international peace and safety, including (i) the design, development, production, stockpiling or any use of weapons of mass destruction such as nuclear, chemical or biological weapons or missiles, (ii) the other military activities, or (iii) any use supporting these activities. You shall not sell, export, dispose of, license, rent, transfer, disclose or otherwise provide our products (technologies) and END Products to any third party whether directly or indirectly with knowledge or reason to know that the third party or any other party will engage in the activities described above.
When exporting, re-export transshipping or otherwise transferring our products (technologies) and END Products, all necessary procedures are to be taken in accordance with Foreign Exchange and Foreign Trade Act (Foreign Exchange Act) of Japan, Export Administration Regulations (EAR) of US, and any other applicable export control laws and regulations promulgated and administered by the governments of the countries asserting jurisdictions over the parties or transaction.

◆Appendix - Supplementary Data

1. Dimensions

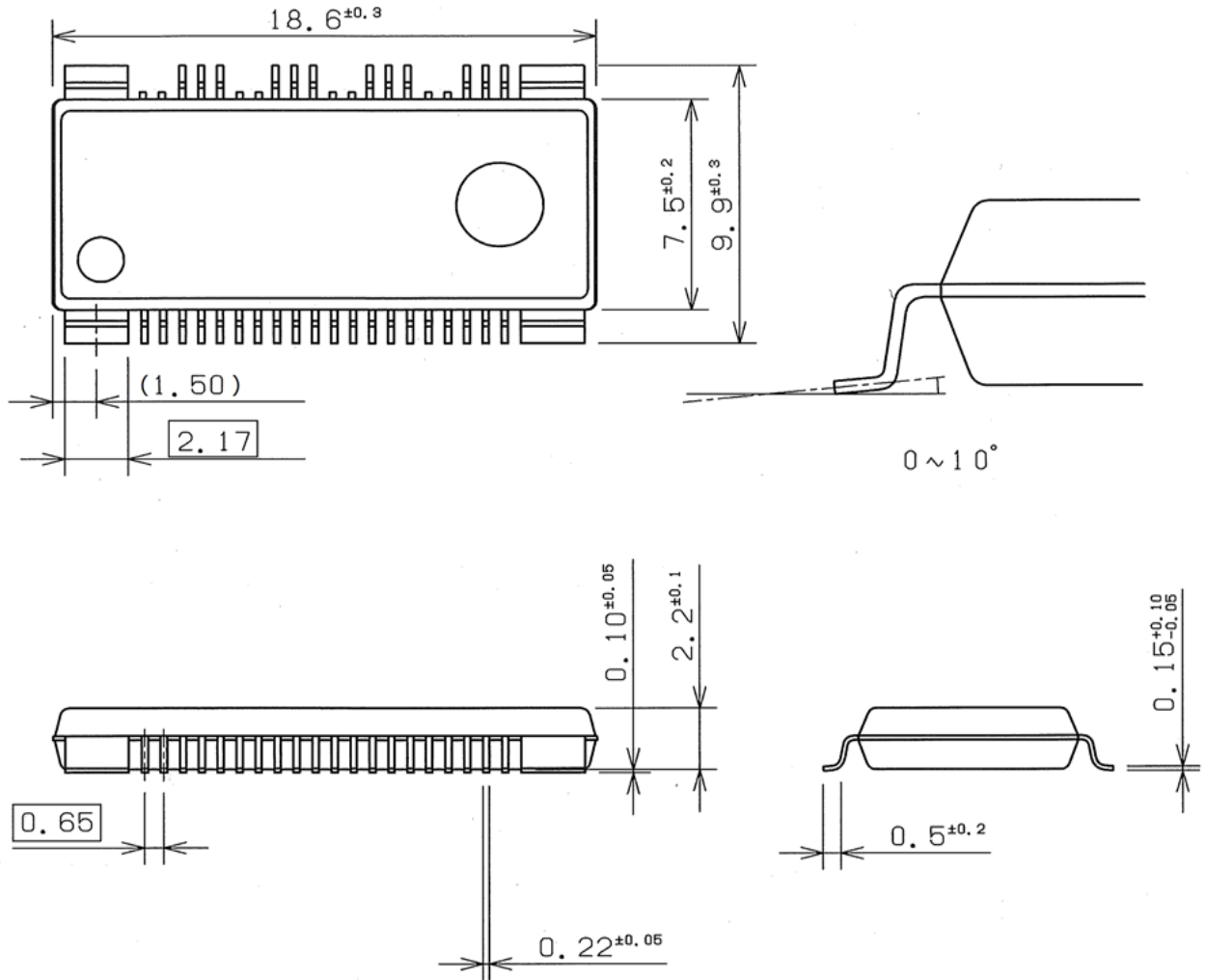

Unit: mm

FIGURE A: Dimensions

2. External Packaging

FIGURE B shows the external packaging. Order quantities are basically multiples of 2000.

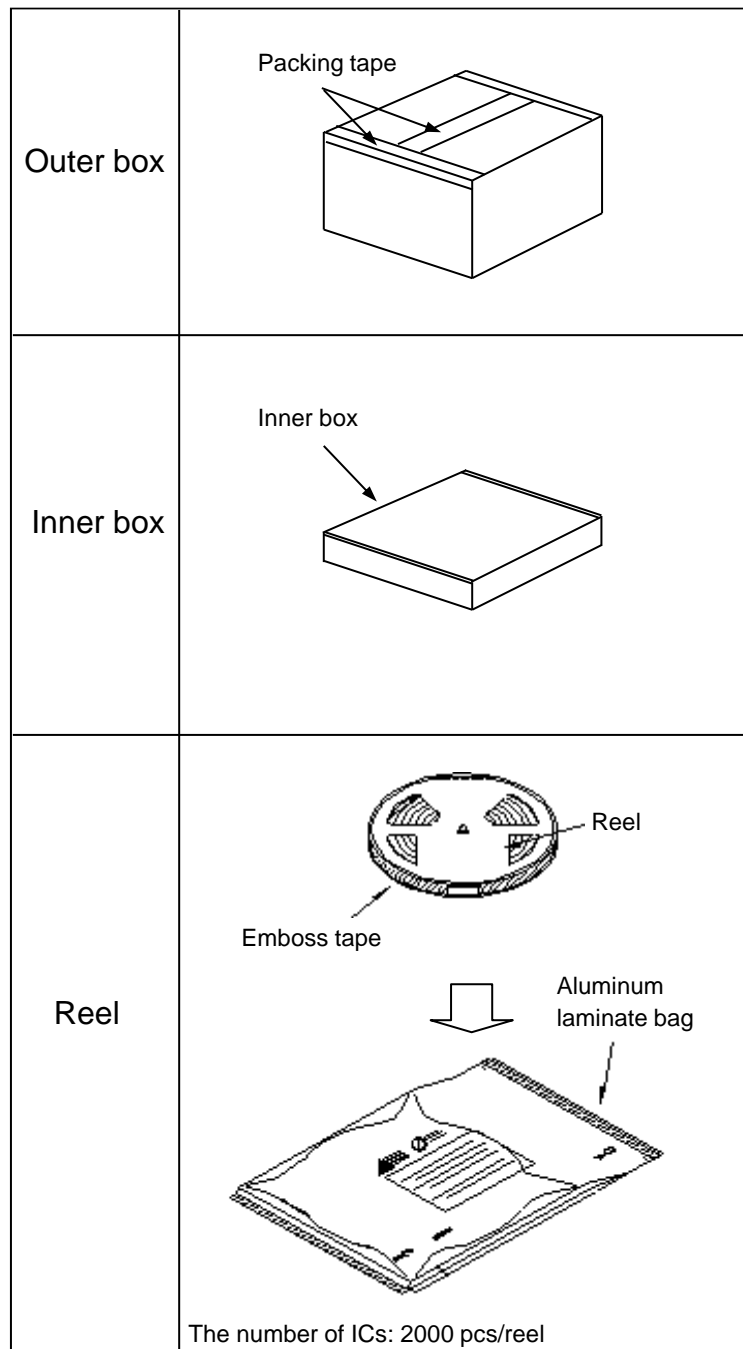

FIGURE B: External Packaging

Precautions for Safe Use and Notices

If semiconductor devices are handled in an inappropriate manner, failures may result. For this reason, be sure to read the latest version of "Instructions for Use of High-Voltage Monolithic ICs" before use.



This mark indicates an item requiring caution.



CAUTION This mark indicates a potentially hazardous situation which, if not avoided, may result in minor or moderate injury and damage to property.



CAUTION

- (1) Regardless of changes in external conditions during use of semiconductor devices, the "maximum ratings" and "safe operating area(SOA)" should never be exceeded when designing electronic circuits that employ semiconductor devices.
- (2) Semiconductor devices may fail due to accidents or unexpected surge voltages. Accordingly, adopt safe design features, such as redundancy and measures to prevent misuse, in order to avoid extensive damage in the event of a failure.
- (3) If semiconductor devices are applied to uses where high reliability is required, obtain the document of permission from MPSD in advance (Automobile, Train, Vessel, etc.). Do not apply semiconductor devices to uses where extremely high reliability is required (Nuclear power control system, Aerospace instrument, Life-support-related medical equipment, etc.).
(If a semiconductor device fails, there may be cases in which the semiconductor device, wiring or wiring pattern will emit smoke or cause a fire or in which the semiconductor device will burst.)

NOTICES

1. This Data Sheet contains the specifications, characteristics, etc. concerning power semiconductor products (hereinafter called "products").
2. All information included in this document such as product data, diagrams, charts, algorithms, and application circuit examples, is current as of the date this document is issued. Such information, specifications of products, etc. are subject to change without prior notice. Before purchasing or using any of the MPSD products listed in this document, please confirm the latest product information with a MPSD sales office.
3. MPSD shall not be held liable in any way for damages and infringement of patent rights, copyright or other intellectual property rights arising from or related to the use of the information, products, and circuits in this document.
4. No license is granted by this document of any patents, copyright or other intellectual property rights of any third party or of MPSD.
5. This document may not be reprinted, reproduced or duplicated, in any form, in whole or in part without the express written permission of MPSD.
6. You shall not use the MPSD products (technologies) described in this document and any other products (technologies) manufactured or developed by using them (hereinafter called "END Products") or supply the MPSD products (technologies) and END Products for the purpose of disturbing international peace and safety, including (i) the design, development, production, stockpiling or any use of weapons of mass destruction such as nuclear, chemical or biological weapons or missiles, (ii) the other military activities, or (iii) any use supporting these activities. You shall not sell, export, dispose of, license, rent, transfer, disclose or otherwise provide the MPSD products (technologies) and END Products to any third party whether directly or indirectly with knowledge or reason to know that the third party or any other party will engage in the activities described above.
When exporting, re-export transshipping or otherwise transferring the MPSD products (technologies) and END Products, all necessary procedures are to be taken in accordance with Foreign Exchange and Foreign Trade Act (Foreign Exchange Act) of Japan, Export Administration Regulations (EAR) of US, and any other applicable export control laws and regulations promulgated and administered by the governments of the countries asserting jurisdictions over the parties or transaction.
7. In no event shall MPSD be liable for any failure in MPSD products or any secondary damage resulting from use at a value exceeding the maximum ratings.

Refer to the following website for the latest information. Contact a MPSD sales office if you have any questions.

<https://www.minebea-psd.com/en>