

Minebea Power Semiconductor Device Inc.

VSP Input Type Single Chip Inverter IC

Application Note

【Rev. 3】

Models

100V AC system	ECN30110
200V AC system	ECN30210

Minebea Power Semiconductor Device Inc.
Design Development Division

— Contents —

1. Outline	3
1.1 System Configuration	3
1.1.1 Single Chip Inverter ICs	3
1.1.2 Composition of Inverter IC	3
1.2 Block Diagram of Inverter IC	4
2. Content of Specifications	4
3. Specifications	5
3.1 IC Types	5
3.2 Pin Locations	6
3.3 Functions of Pins	8
3.4 Markings	13
3.5 Functions and Operational Precautions	15
3.5.1 Protection Function	15
3.5.2 Charge Pump Circuit	19
3.5.3 Power On/Off Sequence	20
3.5.4 VB Power Supply	20
3.5.5 PWM Operation	21
3.5.6 All IGBT Shutoff Function	21
3.5.7 Vcc Standby Function	22
3.5.8 Internal Filter Circuit	22
3.5.9 Calculation of Power Consumption	23
3.5.10 Derating	24
3.5.11 External Parts	25
3.6 Handling	26
3.6.1 Mounting	26
3.6.2 Precautions for Mounting Heat Sink	28
4. Failure Examples (Assumptions)	30
4.1 Electrical Destruction of VSP Pin Caused by External Surge	30
4.2 Electrical Destruction of FG1 and FG2 Pins Caused by External Surge	30
4.3 Inverter IC Destruction by External Surge Inputted to Vs and Vcc (15V) Lines (Case 1)	30
4.4 Inverter IC Destruction by External Surge Inputted to Vs and Vcc (15V) Lines (Case 2)	31
4.5 Inverter IC Destruction by External Surge Inputted to Vs and Vcc (15V) Line (Case 3)	31
4.6 Inverter IC Destruction by External Surge Inputted to Vs and Vcc (15V) Line (Case 4)	31
4.7 Inverter IC Destruction by External Surge Inputted to Vcc (15V) Line	31
4.8 Inverter IC Destruction by Vcc (15V) Line Noise	32
4.9 Inverter IC Destruction by Inspection Machine Relay Noise	32
4.10 Motor Failure (Missing Phase Output)	32
5. Precautions for Use	33
5.1 Countermeasures against Electrostatic Discharge (ESD)	33
5.2 Storage Conditions (applied to: ECN30110F, ECN30110S, ECN30210F, ECN30210S)	33
5.3 Maximum Ratings	33
5.4 Derating Design	33
5.5 Safe Design	34
5.6 Application	34
6. Notes Regarding this Document	34

1. Outline

1.1 System Configuration

1.1.1 Single Chip Inverter ICs

Our single chip inverter ICs are monolithic ICs integrating various constituent devices and circuits required for inverter control on a single chip. They are for driving motors, suited for variable speed control of brushless DC motors. The advantage of downsizing by the use of a single chip structure can be used to reduce the control board in size, which can be incorporated in a motor.

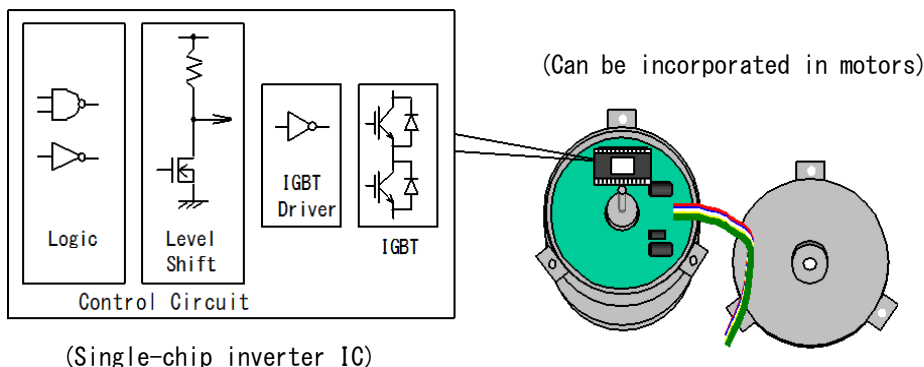

FIGURE 1.1.1.1 Image of Motor with Built-in Control Board

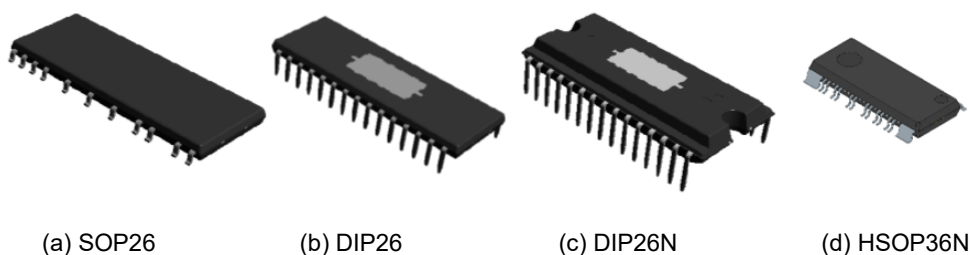

FIGURE 1.1.1.2 Types and Packages of IC

1.1.2 Composition of Inverter IC

An inverter is a device that converts DC currents into AC. It can be used to drive motors for efficient variable-speed control. Figure 1.1.2.1 shows the basic configuration of an inverter IC. To drive the three-phase motor with an inverter, six IGBTs and free wheel diodes are used as output stages. The IC consists of an IGBT driving power circuit, level shift circuit, a logic circuit and other components. Our Inverter ICs can directly receive high voltage supplied from rectifying commercial AC power, because they have high dielectric strength. This obviates the need of a step-down circuit, thus inhibiting efficiency cuts induced by voltage conversion.

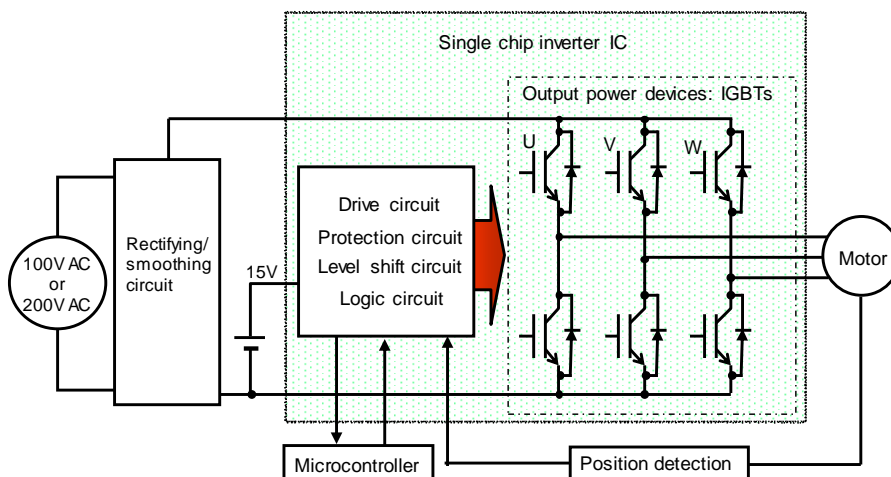
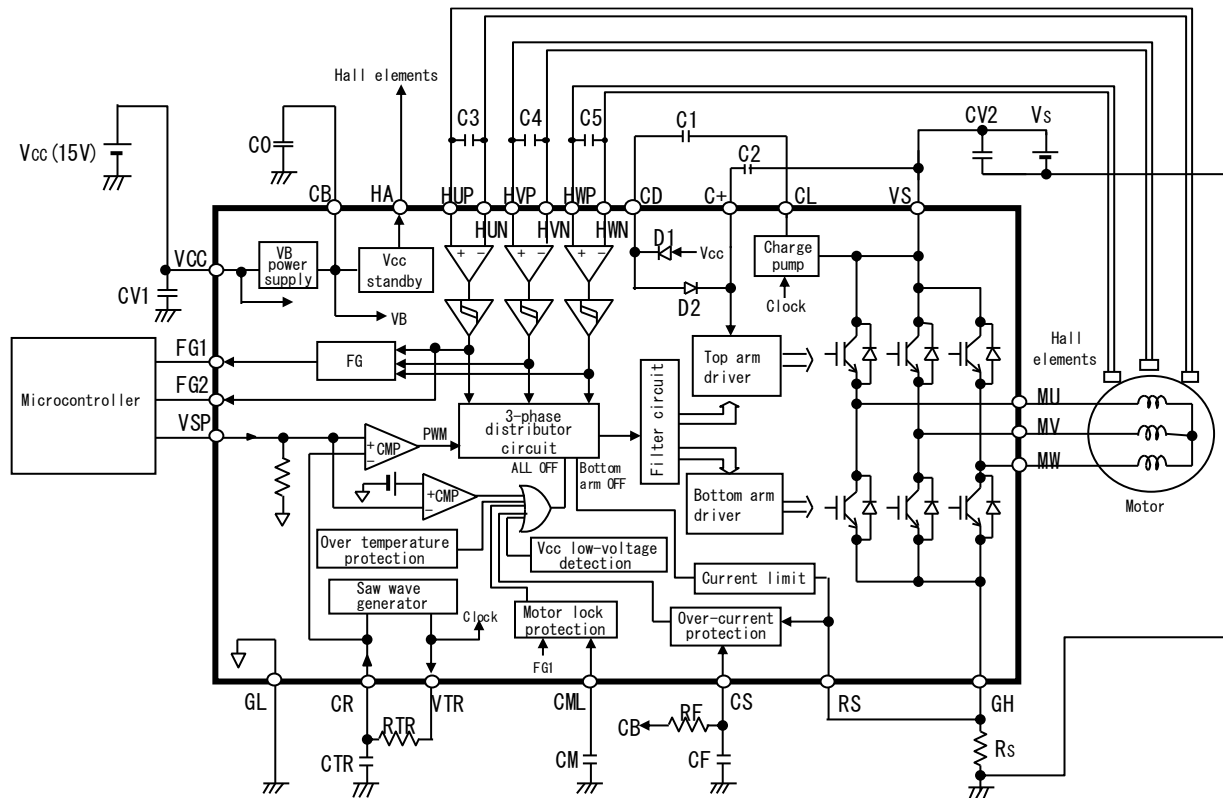

FIGURE 1.1.2.1 Example of Basic Configuration of an Inverter IC

1.2 Block Diagram of Inverter IC

Figure 1.2.1 shows a block diagram of the ECN30110 and ECN30210.

- Hall elements applicable
- Built-in charge pump diodes
- Built-in FG (Frequency Generator) circuits for monitoring motor speed, three pulses and one pulse per cycle
- Various protection functions (current limit, over-current protection, Vcc low-voltage detection, over temperature protection, motor lock protection)



※ Inside of bold line shows the inverter IC (ECN30110, ECN30210)

FIGURE 1.2.1 Block Diagram of Inverter IC

2. Content of Specifications

The following items have been described in the specifications.

- (1) Maximum ratings
 - It describes direct conditions (electric, thermal use conditions) leading to IC destruction and so on. And the safety operating range with operating conditions is shown by minimum or maximum value.
 - In a case the specified values shown in each item are exceeded, products may be damaged or destroyed even for a moment. These specified values should never be exceeded under any operating conditions.
- (2) Electrical characteristics
 - It provides for electric characteristics of the IC, and describes minimum, standard, and maximum.
- (3) Function and operation
 - It describes Truth Table, Timing Chart, Protection Function, and so on.
- (4) Standard application
 - It describes circuit examples and external parts to operate IC.
- (5) SOA and deratings
 - It describes Safe Operation Area (SOA), deratings, and so on.
- (6) Pin assignments and pin definitions
 - It describes pin assignments, pin names and pin definitions.
- (7) Inspection
 - It describes inspection conditions.
- (8) Important notice, precautions
 - It describes notes of the static electricity, the maximum rating, handling, and so on.
- (9) Appendix and reference data
 - It describes packaging and dimensions.

3. Specifications

3.1 IC Types

Table 3.1.1 shows ratings, package types, and mounting types of the ICs.

TABLE 3.1.1 IC and Package Types

No.	Type	Maximum ratings	Package type	Mounting type
1	ECN30110F	Output device withstand voltage : 250V Output current (Pulse) : 1.4A Output current (DC) : 1.0A	SOP26	Surface mount type
2	ECN30110P		DIP26	Pin insertion type
3	ECN30110PN		DIP26N	Pin insertion type
4	ECN30110S		HSOP36N	Surface mount type
5	ECN30210F	Output device withstand voltage : 600V Output current (Pulse) : 1.5A Output current (DC) : 0.7A	SOP26	Surface mount type
6	ECN30210P		DIP26	Pin insertion type
7	ECN30210PN		DIP26N	Pin insertion type
8	ECN30210S		HSOP36N	Surface mount type

3.2 Pin Locations

Table 3.2.1 shows pin locations of ECN30110F, ECN30110P, ECN30110PN, ECN30210F, ECN30210P, and ECN30210PN.

Table 3.2.2 shows pin locations of ECN30110S and ECN30210S.

TABLE 3.2.1 Pin Locations (ECN30110F, ECN30110P, ECN30110PN, ECN30210F, ECN30210P, ECN30210PN)

Pin No.	Symbol	Pin functions	Remarks
1	CL	For the charge pump circuit	Note 1
2	CD	For the charge pump circuit	Note 1
3	C+	For the charge pump circuit	Note 1
4	VS	High voltage power supply	Note 1
5	MW	W phase output	Note 1
6	MV	V phase output	Note 1
7	MU	U phase output	Note 1
8	GH	Emitters of bottom arm IGBTs and anodes of bottom arm FWDs (Connected to a shunt resistor)	
9	RS	Input for current limit and over-current protection	
10	FG2	Output for motor rotational speed monitor (one pulse / 360 electrical degrees)	
11	FG1	Output for motor rotational speed monitor (three pulses / 360 electrical degrees)	
12	HUN	U phase Hall signal minus input	
13	HUP	U phase Hall signal plus input	
14	HVN	V phase Hall signal minus input	
15	HVP	V phase Hall signal plus input	
16	HWN	W phase Hall signal minus input	
17	HWP	W phase Hall signal plus input	
18	CML	For motor lock protection	
19	VTR	Connect a resistor to set the PWM frequency	
20	CR	Connect a resistor and a capacitor to set the PWM frequency	
21	HA	Output for Vcc standby function	
22	CS	For over-current protection	
23	CB	VB power supply output	
24	VSP	Analog speed command signal input	
25	VCC	15V power supply	
26	GL	Ground	

Note 1: High voltage pin. The voltage between CD and CL and between C+ and VS are low. Therefore, the distances between these pins are the same as those between low voltage pins.

Note 2: The voltage at exposed tab is the same as GL pin.

TABLE 3.2.2 Pin Locations (ECN30110S, ECN30210S)

Pin No.	Symbol	Pin functions	Remarks
1,22,23,36	GL	Ground	
2	NC	No connection	Note 2
3	VCC	15V power supply	
4	NC	No connection	Note 2
5	NC	No connection	Note 2
6	NC	No connection	Note 2
7	VSP	Analog speed command signal input	
8	CB	VB power supply output	
9	CS	For over-current protection	
10	HA	Output for Vcc standby function	
11	CR	Connect a resistor and a capacitor to set the PWM frequency	
12	VTR	Connect a resistor to set the PWM frequency	
13	CML	For motor lock protection	
14	HWP	W phase Hall signal plus input	
15	HWN	W phase Hall signal minus input	
16	HVP	V phase Hall signal plus input	
17	HVN	V phase Hall signal minus input	
18	HUP	U phase Hall signal plus input	
19	HUN	U phase Hall signal minus input	
20	FG1	Output for motor rotational speed monitor (three pulses / 360 electrical degrees)	
21	FG2	Output for motor rotational speed monitor (one pulse / 360 electrical degrees)	
24	RS	Input for current limit and over-current protection	
25	GH	Emitters of bottom arm IGBTs and anodes of bottom arm FWDs (Connected to a shunt resistor)	
26	NC	No connection	Note 2
27	MU	U phase output	Note 1
28	NC	No connection	Note 2
29	MV	V phase output	Note 1
30	NC	No connection	Note 2
31	MW	W phase output	Note 1
32	VS	High voltage power supply	Note 1
33	C+	For the charge pump circuit	Note 1
34	CD	For the charge pump circuit	Note 1
35	CL	For the charge pump circuit	Note 1

Note 1: High voltage pin. The voltage between CD and CL and between C+ and VS are low. Therefore, the distances between these pins are the same as those between low voltage pins.

Note 2: Not connected to the chip in the IC.

3.3 Functions of Pins

TABLE 3.3.1 List of Pins and Functions (1/5)

No.	Pin	Items	Functions and Precautions	Related items	Remarks
1	VCC	Analog / Logic power supply	<ul style="list-style-type: none"> • Powers the drive circuits for the top and bottom arms, the charge pump circuit, the built-in VB supply circuit, and others. • Determine the capacity of the power supply for Vcc (15V) allowing for a margin determined by adding the standby current ICC and the current taken out of CB and HA pins. 	<ul style="list-style-type: none"> • 3.5.1 (1) Vcc low-voltage detection • 3.5.3 Power on/off sequence • 4.3 to 4.8 Inverter IC destruction by surge or noise 	
2	VS	IGBT power pin	<ul style="list-style-type: none"> • Connected to the collectors of the top arm IGBTs. 	<ul style="list-style-type: none"> • 3.5.3 Power on/off sequence • 4.3 to 4.6 Inverter IC destruction by surge 	High voltage pin
3	CB	VB power supply output	<ul style="list-style-type: none"> • Outputs a voltage (typ. 7.5V) generated in the built-in VB power supply. • VB supply powers the IC internal circuits (input buffer, over-current protection and others) and can be used as a power supply for external circuits such as Hall elements and so on. • Connect an oscillation prevention capacitor C0 (1.0μF\pm10% recommended) to the CB pin. 	<ul style="list-style-type: none"> • 3.5.4 VB power supply 	
4	GL	Analog / Logic ground	<ul style="list-style-type: none"> • It is the ground pin for Vcc (15V) and VB power lines. • HSOP36N has 4 GL pins connected inside the IC. Do not allow Vs power supply current (shunt resistor current) to flow from any GL pin to the other GL pin. (e.g. Avoid flowing the Vs power supply current from Pin No.23 to Pin No.1.) If the Vs power supply current flows, the GND potential inside the IC will fluctuate, perhaps resulting in the IC malfunctioning. 	—	
5	GH	IGBT emitter pin	<ul style="list-style-type: none"> • The GH pin is connected to the emitters of U, V and W-phase bottom arm IGBTs. • The GH pin is connected to a shunt resistor Rs to perform current limit and over-current protection. • Make the wiring of the shunt resistor Rs as short as possible. If the wiring has high resistance or inductance, the emitter potential of the IGBT changes, perhaps resulting in the IGBT malfunctioning. 	<ul style="list-style-type: none"> • 3.5.1 (2) Current limit (3) Over-current protection 	
6	MU MV MW	Inverter output pin	<ul style="list-style-type: none"> • These are outputs of a three-phase bridge consisting of six IGBTs and free wheel diodes. 		High voltage pin

TABLE 3.3.1 List of Pins and Functions (2/5)

No.	Pin	Items	Functions and Precautions	Related items	Remarks
7	RS CS	For current limit and over-current protection	<ul style="list-style-type: none"> Monitors the voltage of the Rs shunt resistor using the RS pin and detects over current status. When the over-current protection is used, connect an external capacitor CF and an external resistor RF to the CS pin. When not used, connect the CS pin to the CB pin. 	<ul style="list-style-type: none"> 3.5.1 (2) Current limit (3) Over-current protection 	
<p>FIGURE 3.3.1 Equivalent Circuit around RS, CS Pins</p>					
8	HUP HUN HVP HVN HWP HWN	Hall signal input	<ul style="list-style-type: none"> The potential difference between HUP and HUN, HVP and HVN, HWP and HWN decides internal logic. The maximum input voltage is VB+0.5V. If the IC malfunctions due to a noise, install a capacitor. The influence of noise can be found out by monitoring FG1 signal. 	<ul style="list-style-type: none"> Product Specification Truth table Timing chart 	
<p>FIGURE 3.3.2 Equivalent Circuit around Hall Signal Pins</p>					

TABLE 3.3.1 List of Pins and Functions (3/5)

No.	Pin	Items	Functions and Precautions	Related items	Remarks
9	C+ CL CD	Top arm drive circuit power pin, Charge pump circuit pin	<ul style="list-style-type: none"> • Powers the drive circuit for the top arm. • Connect a capacitor between C+ and VS, CD and CL, respectively. 	<ul style="list-style-type: none"> • 3.5.2 Charge pump circuit 	High voltage pin
10	FG1 FG2	Output for motor rotational speed monitor	<ul style="list-style-type: none"> • Output pulses in synchronization with the input signals of the HUP, HUN, HVP, HVN, HWP and HWN. • Motor rotation speed can be monitored by measuring the frequency of output pulse. • FG1 output pulse is three pulses per cycle. • FG2 output pulse is one pulse per cycle. 	<ul style="list-style-type: none"> • 4.2 Electrical destruction of FG1 and FG2 pins caused by external surge • Product Specification Truth table Timing chart 	

TABLE 3.3.1 List of Pins and Functions (4/5)

No.	Pin	Items	Functions and Precautions	Related items	Remarks
11	VSP	Analog speed command signal input	<ul style="list-style-type: none"> • Input a speed command signal to generate a PWM signal. • If a noise is detected, install a resistor and/or capacitor. 	<ul style="list-style-type: none"> • 3.5.3 Power on/off sequence • 3.5.5 PWM operation • 3.5.6 All IGBT shutoff function • 4.1 Electrical destruction of VSP pin caused by external surge 	
<p>FIGURE 3.3.5 Equivalent Circuit around VSP Pin</p>					
12	CR VTR	PWM frequency setting pin	<ul style="list-style-type: none"> • Externally connected resistor and capacitor are used to determine the PWM frequency (internal clock). • The PWM frequency is approximated by the following equation. $f \approx 0.494 / (C \times R) \text{ (Hz)}$ 	<ul style="list-style-type: none"> • 3.5.5 PWM operation 	
<p>FIGURE 3.3.6 Equivalent Circuit around CR, VTR Pins</p>					

TABLE 3.3.1 List of Pins and Functions (5/5)

No.	Pin	Items	Functions and Precautions	Related items	Remarks
13	CML	For motor lock protection	<ul style="list-style-type: none"> When the motor lock protection is used, connect an external capacitor CM. When not used, connect this pin to the GL pin. 	<ul style="list-style-type: none"> 3.5.1 (4) Motor lock protection 	
<p>FIGURE 3.3.7 Equivalent Circuit around CML Pin</p>					
14	HA	Output pin for Vcc standby function	<ul style="list-style-type: none"> When the Vcc standby function is used, use this pin as a power supply for the Hall elements. When not used, connect this pin to the CB pin or do not connect anything to this pin. 	<ul style="list-style-type: none"> 3.5.7 Vcc standby function 	
<p>FIGURE 3.3.8 Equivalent Circuit around HA Pin</p>					

3.4 Markings

The resin surface of the IC is marked by laser.

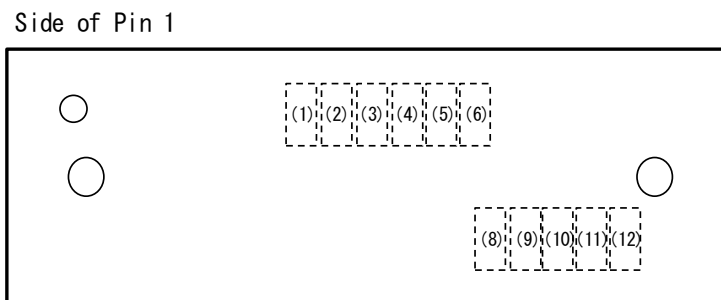

Side of Pin 26

FIGURE 3.4.1 SOP26 Marking Specifications

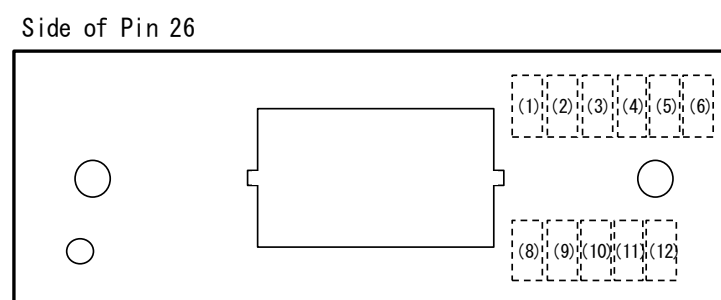

Side of Pin 1

FIGURE 3.4.2 DIP26 Marking Specifications

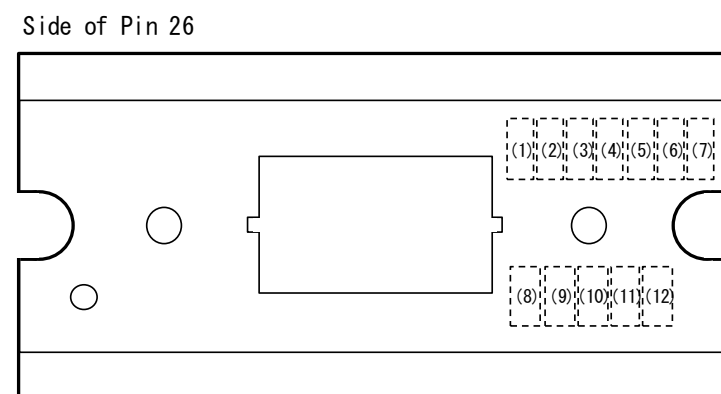

Side of Pin 1

FIGURE 3.4.3 DIP26N Marking Specifications

Mark No. (1) to (7) : Model name

Mark No. (8) to (12) : Lot number

The lot number consists of the followings.

No. (8) : Last one-digit of the year of assembly

No. (9) : Month of assembly:

January: A, February: B, March: C April: D, May: E, June: K,

July: L, August: M, September: N, October: X, November: Y, December: Z

No. (10) to (12) : Quality control number

Represented with letters from "A" to "Z" except "I" and "O", numbers from "0" to "9", or blank.

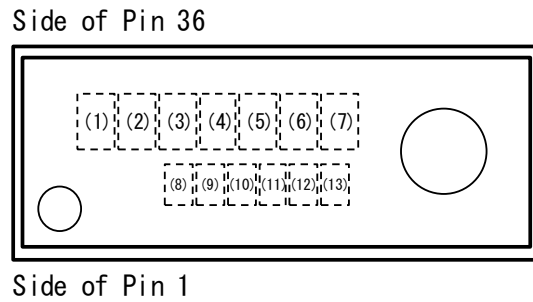

FIGURE 3.4.4 HSOP36N Marking Specifications

Mark No. (1) to (7) : Model name

Mark No. (8) to (13) : Lot number

The lot number consists of the followings.

No. (8) (9) : Last two digits of the year of assembly

No. (10) : Month of assembly :

January: A, February: B, March: C April: D, May: E, June: K,

July: L, August: M, September: N, October: X, November: Y, December: Z

No. (11) to (13) : Quality control number

Represented with letters from "A" to "Z" except "I" and "O", numbers from "0" to "9", or blank.

3.5 Functions and Operational Precautions

3.5.1 Protection Function

(1) Vcc low-voltage detection

Our company calls the Vcc (15V) low-voltage detection “LVSD”. When the Vcc (15V) voltage drops below the LVSD operating voltage (LVSDON), all IGBTs (top and bottom arms) are turned off regardless of the input signals. This function has hysteresis. When the Vcc voltage goes up again, the system returns to a state in which the output IGBTs operate depending on the input signals, at a level equal to or exceeding the LVSD recovery voltage (LVSDOFF).

If the Vcc low-voltage detection operates during motor rotation, Vs voltage may rise due to regenerative electric power to the Vs power supply. The Vs voltage must not exceed the maximum rating. Particular attention is needed when the capacitance of a capacitor between the VS and GND is small, because it makes the voltage more likely to rise.

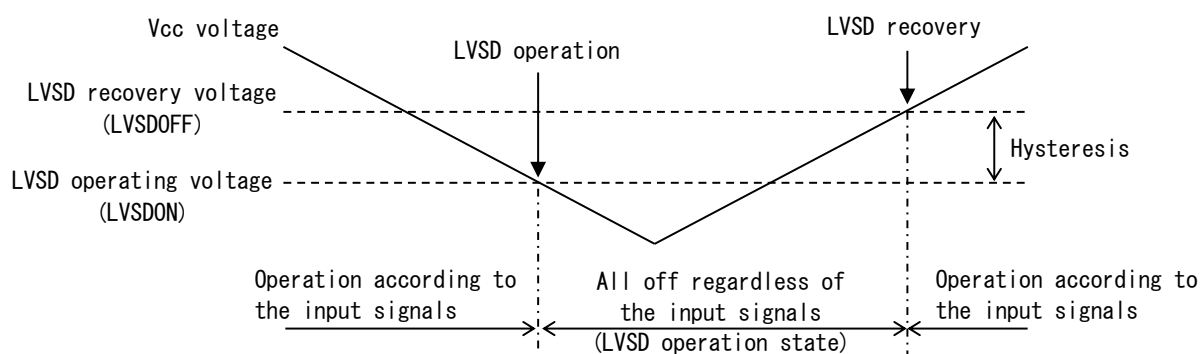

FIGURE 3.5.1.1 Timing Chart for Vcc Low-voltage Detection (LVSD Operation)

(2) Current limit

(a) Operation

The IC detects the current using the voltage at the RS pin. When the voltage at the RS pin exceeds the Vref1 (typ. 0.5V) of the internal detection circuit, the bottom arm IGBTs are all turned off. Reset after current limit operation is performed in each cycle of the internal clock signal (VTR pin voltage).

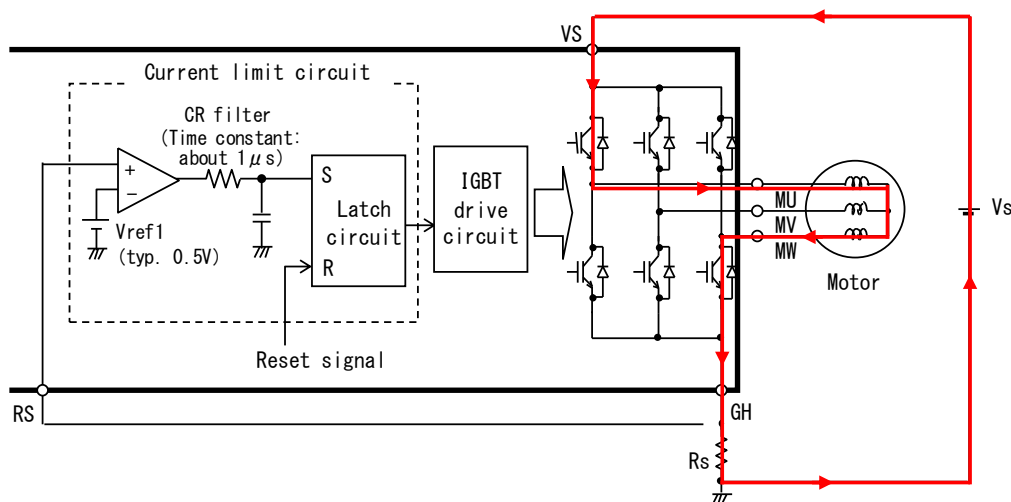

FIGURE 3.5.1.2 Equivalent Circuit of Current Limit Circuit and Example of Current of Shunt Resistor

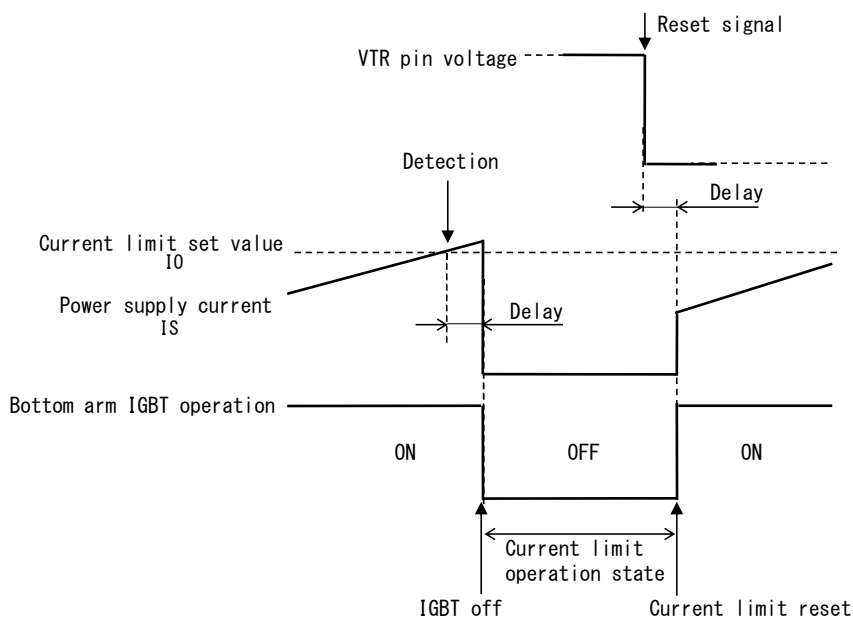

FIGURE 3.5.1.3 Timing Chart for Current Limit

(b) How to set up

The current limit set value (I_O) is calculated as follows;

$$I_O = V_{ref1}/R_s$$

Where

V_{ref1} : Current limit reference voltage

R_s : Shunt resistance value

In setting a current limit, delay time to turn the output IGBT off and variability of V_{ref1} and R_s need to be considered. Observe the output currents of the IC (the coil currents of the motor) and confirm a design margin.

This function is not effective for currents that do not flow forward (direction to the GL pin) through the shunt resistor, such as reflux current and power regenerative current (see Figs. 3.5.1.4 and 3.5.1.5).

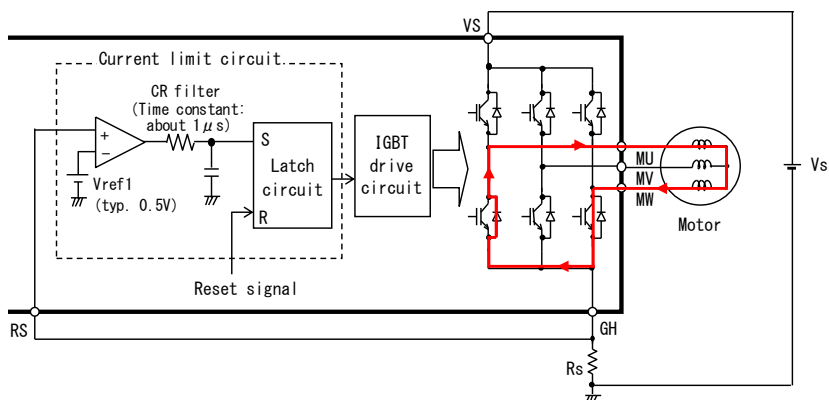

FIGURE 3.5.1.4 Example of Reflux Current

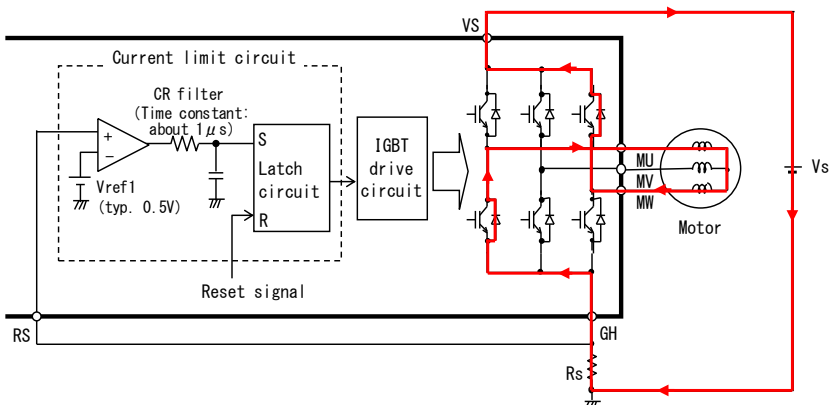

FIGURE 3.5.1.5 Example of Power Regenerative Current

(3) Over-current protection

(a) Operation

Figure 3.5.1.6 shows an equivalent circuit of the over-current protection circuit. Figure 3.5.1.7 shows a timing chart for the over-current protection operation.

When the voltage at the RS pin exceeds the V_{ref2} (typ. 1.0V), the M1 is turned on, and the capacitor CF is discharged. When the voltage at the CS pin drops below the threshold voltage V_{th1} of the Schmitt circuit, the IGBTs of the top and bottom arms are all turned off. When the IGBTs are turned off, and the voltage at the RS pin drops below the V_{ref2} , the M1 is turned off, and the capacitor CF is charged through the resistor RF. When the voltage at the CS pin exceeds the threshold voltage V_{th2} of the Schmitt circuit, the IC returns to a state in which the IGBTs operate.

(b) Notice

Recommended constants of the external parts are $C_F=470\text{pF}$ and $R_F=2\text{M}\Omega$. If these constants are changed, the delay time may increase, or the heat generation may increase due to a reduction in recovery time.

Mount the capacitor CF as close to the IC as possible so as not to be affected by noise.

If the voltage at the CS pin is measured with a measuring instrument such as an oscilloscope (in evaluation, etc.) recovery voltage may change because of the influence of the current flowing through a measuring instrument.

When the IGBTs of the top and bottom arms are all turned off by operation of this protection or other function during motor driving, the power supply voltage may rise as a result of a regenerative current flow. The power supply voltage must not exceed the maximum rating.

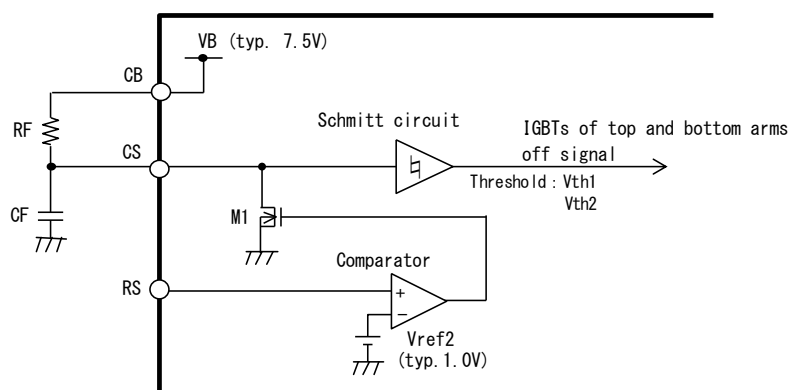

FIGURE 3.5.1.6 Equivalent Circuit of Over-current Protection Circuit

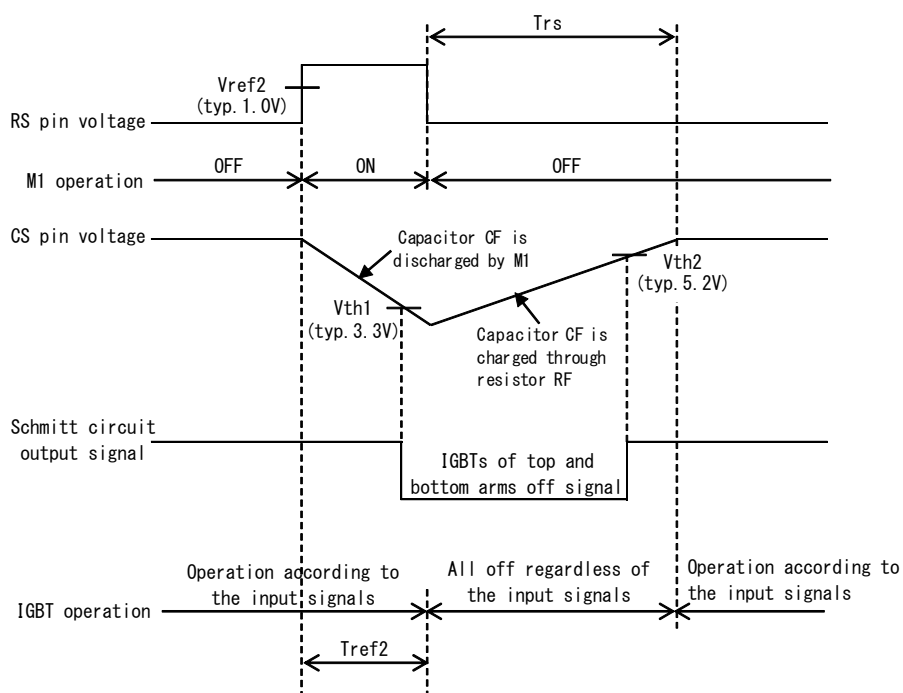

FIGURE 3.5.1.7 Timing Chart for Over-current Protection Operation

(4) Motor lock protection

(a) Operation

Figures 3.5.1.8 shows an equivalent circuit of the motor lock protection circuit. Figure 3.5.1.9 shows a timing chart of the motor lock protection. The motor lock protection detects a lock state of the motor from a cycle of the FG1 signal.

- Period I : While the motor is rotating, the SW1 is turned on, and the CM is charged. The M1 is turned on, and the CM is discharged at the rising edge of the FG1. (These operations are repeated while the motor is rotating.)
- Period II : When the motor becomes in a lock state, and the voltage reaches the V_{th2} , the motor lock state is detected, and the IGBTs of the top and bottom arms are all turned off.
- Period III : When the motor lock state is detected, the SW1 is turned off, and the SW2 is turned on, and the CM is discharged. When the voltage goes down to the V_{th1} , the IC returns to a state in which the IGBTs operate.
- Period IV : The SW1 is turned on, and the SW2 is turned off, causing the CM to be charged. If the voltage goes up to the V_{th2} , the motor lock state is detected again.
(In the motor lock state, the operations of the Periods III and IV are repeated.)
- Period V : When the motor becomes in the motor rotating state, the M1 is turned on at the rising edge of the FG1, and the CM is discharged.

Regarding information on using this function such as the method for setting operating time and recovery time, see Section 2.4.8 in the *Product Specification*.

(b) Notice

Mount the capacitor CM as close to the IC as possible so as not to be affected by noise.

If the voltage at the CML pin is measured with a measuring instrument such as an oscilloscope, for example, in evaluation, the operating time and the recovery time may change because of the influence of the current flowing through a measuring instrument.

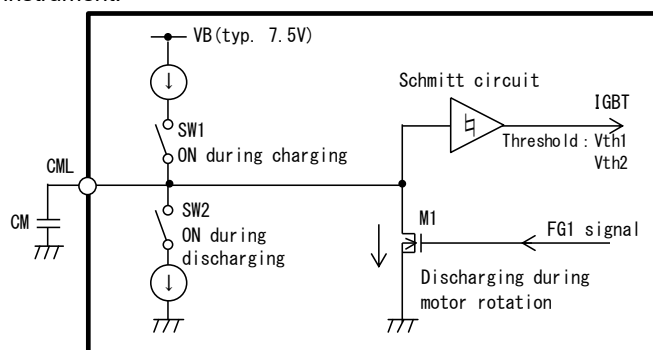

FIGURE 3.5.1.8 Equivalent Circuit of Motor Lock Protection Circuit

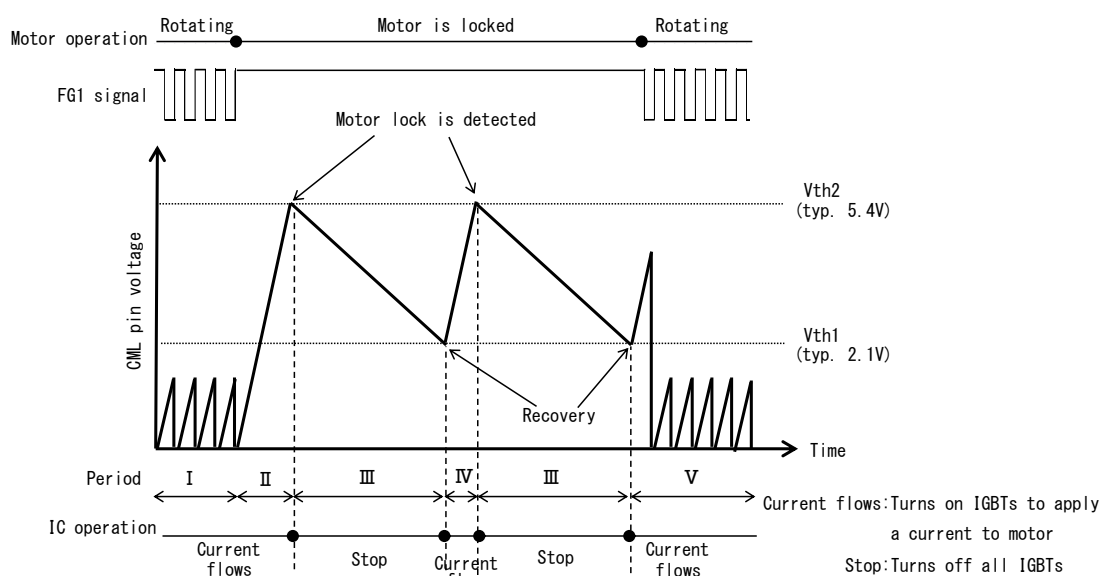

FIGURE 3.5.1.9 Timing Chart for Motor Lock Protection and Recovery Operations

(5) Over temperature protection

Figure 3.5.1.10 shows a timing chart for the over temperature protection operation. When the IC temperature reaches or exceeds the operating temperature of over temperature protection (TSDON = typ. 170°C), the IGBTs of the top and bottom arms are all turned off regardless of the input signals. When the IC temperature goes down to the recovery temperature of the over temperature protection (TSDOFF = typ. 145°C), the IC returns to a state in which the IGBTs operate according to input signals.

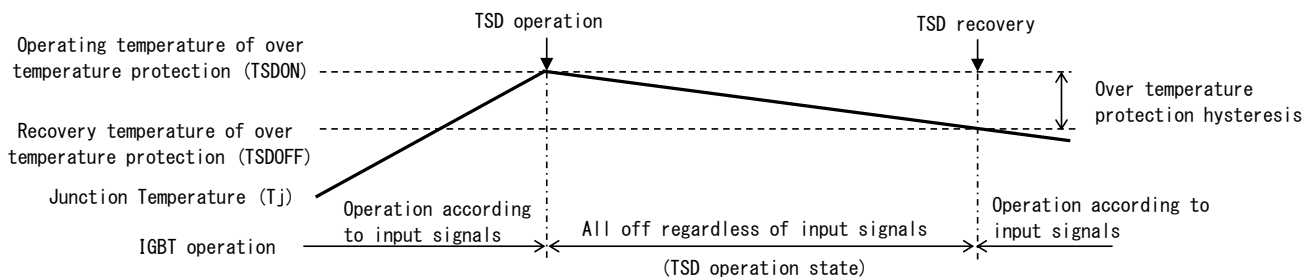

FIGURE 3.5.1.10 Timing Chart for Over Temperature Protection Operation

3.5.2 Charge Pump Circuit

3.5.2.1 Operation of Charge Pump Circuit

Figure 3.5.2.1 shows a block diagram of the charge pump circuit. When 15V is inputted to the VCC pin, SW1 and SW2 alternately turn on and off.

- ① When SW1 is off and SW2 is on, the CL pin has a potential of 0V. Through passage (a), capacitor C1 is charged.
- ② When SW1 is turned on and SW2 is turned off, the potential of the CL pin rises to the V_s level. Through passage (b), the charge of capacitor C1 is pumped up to capacitor C2.

These operations ① and ② are repeated with the frequency of the internal clock, and the charge is given to capacitor C2.

Capacitor C2 constitutes a power supply for the drive circuit for the top arm.

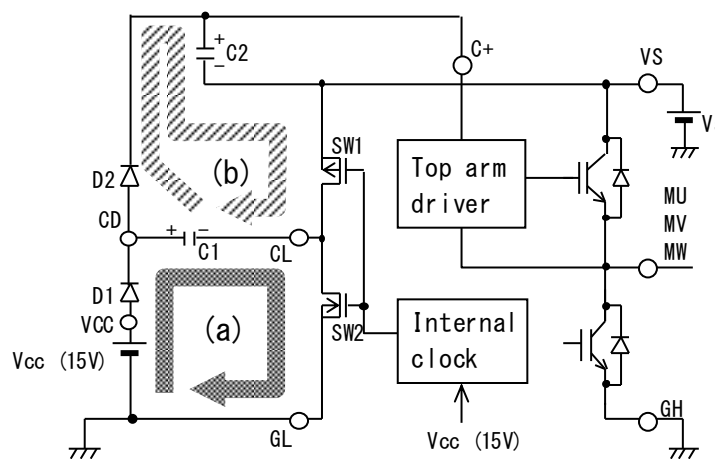

FIGURE 3.5.2.1.1 Charge Pump Circuit

3.5.3 Power On/Off Sequence

(1) ECN30110

Current of the IGBT is not saturated regardless of the power on/off sequence of the Vcc power supply, Vs power supply, and Vsp voltage.

However, if the motor lock protection is enabled and Vs is powered on after the Vcc and Vsp power-on, the start-up may be delayed by the motor lock protection operation.

(2) ECN30210

When the output pin current is 1A or less, current of the IGBT is not saturated regardless of the power on/off sequence of the Vcc power supply, Vs power supply, and Vsp voltage.

However, if the motor lock protection is enabled and Vs is powered on after the Vcc and Vsp power-on, the start-up may be delayed by the motor lock protection operation.

When the output pin current is no less than 1A, the following sequences are recommended.

- At power-on : Vcc on → Vs on → Vsp on
- At power-off : Vsp off → Vs off → Vcc off

If any sequence is involved other than those specified above, please refer to Tables 3.5.3.1 and 3.5.3.2.

When the sequence is No. 4 or No. 6 in Table 3.5.3.1 or No. 4 or No. 6 in Table 3.5.3.2, see the section of "Power On/Off Sequence and Current Derating for Vcc" of the Product Specification.

TABLE 3.5.3.1 Power On Sequence

No	①	→ ②	→ ③	Permit or Inhibit
1	Vcc	Vs	Vsp	Permit
2	Vcc	Vsp	Vs	Permit
3	Vs	Vcc	Vsp	Permit
4	Vs	Vsp	Vcc	Inhibit
5	Vsp	Vcc	Vs	Permit
6	Vsp	Vs	Vcc	Inhibit

TABLE 3.5.3.2 Power Off Sequence

No	①	→ ②	→ ③	Permit or Inhibit
1	Vsp	Vs	Vcc	Permit
2	Vs	Vsp	Vcc	Permit
3	Vsp	Vcc	Vs	Permit
4	Vcc	Vsp	Vs	Inhibit
5	Vs	Vcc	Vsp	Permit
6	Vcc	Vs	Vsp	Inhibit

3.5.4 VB Power Supply

The VB voltage (typ. 7.5V) is generated from the Vcc (15V) power supply and outputted from the CB pin. When the voltage at the VSP pin is higher than the all off operating voltage (typ.1.23V), the VB voltage is also outputted from the HA pin through the internal device. The VB power is supplied to the IC internal circuits such as the over-current protection circuit. Figure 3.5.4.1 shows an equivalent circuit. This circuit constitutes a feedback circuit.

To prevent oscillation, connect a capacitor C0 to the CB pin. The recommended capacitance for the C0 is 1.0μF±10%.

The larger the C0 capacity, the more stable the VB power supply. However, excessive capacitance is not recommended.

As a guide, it should be 2μF to 3μF or less.

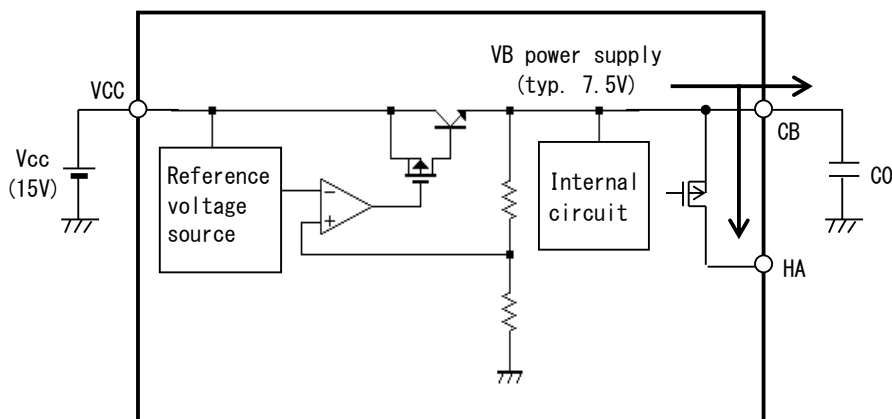

FIGURE 3.5.4.1 Equivalent Circuit for VB Power Supply

3.5.5 PWM Operation

PWM signals are generated by comparing the VSP input voltage and internal triangular signal (CR pin voltage). Figure 3.5.5.1 shows the relation between the PWM duty and VSP input voltage. The PWM duty indicates the duty of the IGBT gate drive signals. The voltages at the output pins (MU, MV, MW) may differ from those shown in Figure 3.5.5.1 depending on use conditions. PWM switching is conducted by the bottom arms. Figure 3.5.5.2 shows the timing chart of PWM operation.

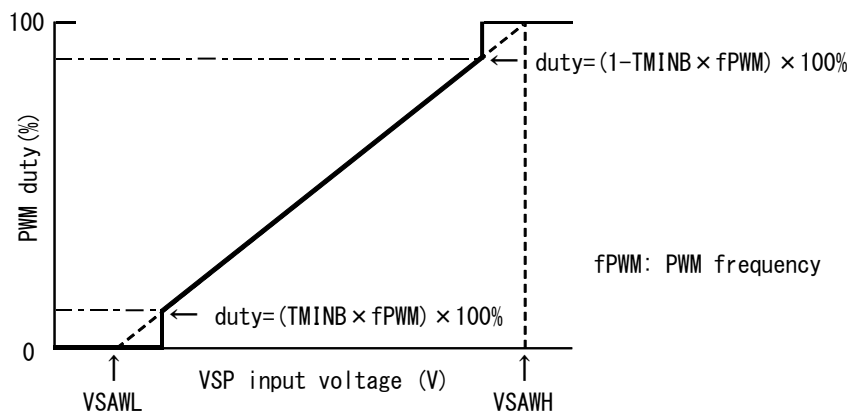

FIGURE 3.5.5.1 Relation between VSP Input Voltage and PWM Duty

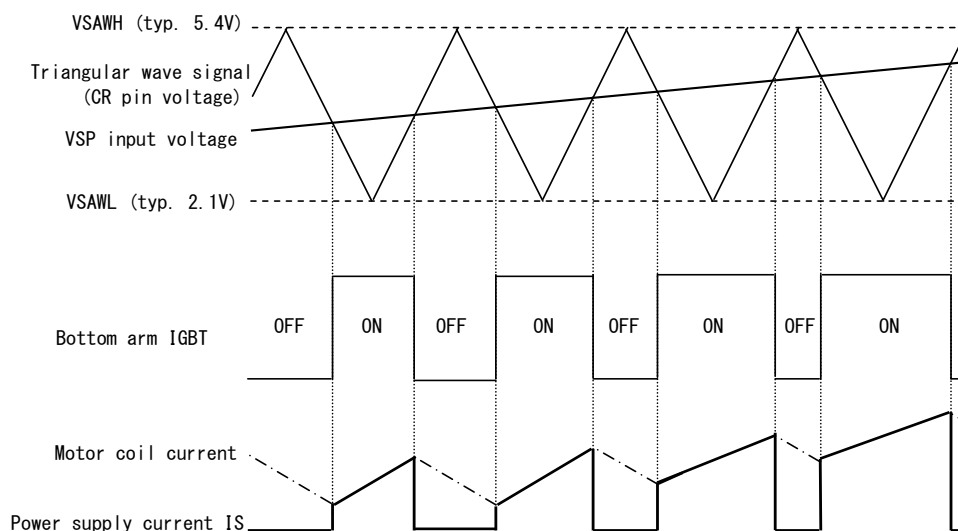

FIGURE 3.5.5.2 Timing Chart of PWM Operation

3.5.6 All IGBT Shutoff Function

When the input voltage at the VSP pin drops below VSAWL (typ. 2.1V), the IC stops the motor drive. When the input voltage at the VSP pin drops further from VSAWL and becomes below Voff (typ. 1.23V), the IGBTs (top and bottom arms) are all shut off to reduce current consumption within the IC. The state of the output IGBTs with regard to the VSP input voltage is shown in Table 3.5.6.1.

TABLE 3.5.6.1 State of Output IGBTs with Regard to VSP Input Voltage

VSP input voltage	Motor drive state	Top arm IGBTs	Bottom arm IGBTs
$0V \leq VSP < Voff$	Stop	All off	All off
$Voff \leq VSP < VSAWL$		Based on Hall signal inputs	All off
$VSAWL \leq VSP$	Drive	Based on Hall signal inputs	Based on Hall signal inputs

3.5.7 Vcc Standby Function

When the input voltage at the VSP pin is more than the all off operating voltage (typ.1.23V), the internal element is turned on, and the current is applied from the HA pin to the Hall elements.

When the input voltage at the VSP pin is less than the all off operating voltage, the internal element is turned off, and the current to the Hall elements is shut off to reduce standby power consumption from Vcc power supply.

When the current to the Hall elements is shut off, the voltages at the Hall signal input pins (H*P, H*N) are all fixed at "L". At this time, the FG1 and the FG2 output "L". If there is a need to confirm the motor rotating state through the FG1 or the FG2 output signal while the VSP input voltage is below the all off operating voltage, do not use this function (the HA pin). Use the CB pin as the power supply for the Hall elements.

When this function is not used, open the HA pin or connect it to the CB pin.

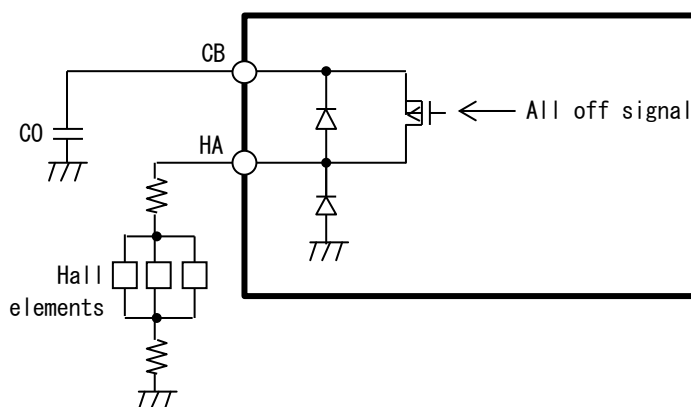

FIGURE 3.5.7.1 Usage Example of Hall Elements and Internal Equivalent Circuit

3.5.8 Internal Filter Circuit

Internal filter circuits are located before the top and bottom arm drivers. The filter circuits remove signals and switching noise with widths less than about 0.5μs.

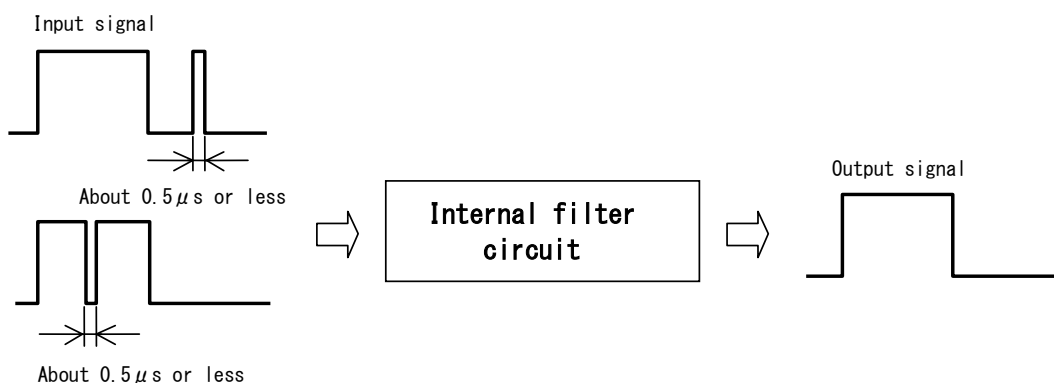

FIGURE 3.5.8.1 Operation of Internal Filter Circuit

3.5.9 Calculation of Power Consumption

(1) Power consumption

This IC applies the 120-degree energization method. Here are simple formulae for calculating of power consumption. As for the constants required for calculation, contact our sales representative.

Total IC power consumption ; $P = P_{igbt} + P_{fwd} + P_{sw} + P_r + P_{is} + P_{icc}$ (W)

- ① Steady-state power dissipation of IGBTs
 $P_{igbt} = I_{ave} \times V_{ONT} + I_{ave} \times V_{ONB} \times D$ (W)
 - ② Steady-state power dissipation of Free Wheeling Diodes (FWDs)
 $P_{fwd} = I_{ave} \times V_{FDT} \times (1 - D)$ (W)
 - ③ Switching power dissipation of IGBTs
 $P_{sw} = (E_{on} + E_{off}) \times f_{PWM}$ (W)
 - ④ Recovery power dissipation of FWDs
 $P_r = 1/4 \times (I_{rrT} \times V_s \times t_{rrT} \times f_{PWM})$ (W)
 - ⑤ Power consumption in high voltage circuit
 $P_{is} = V_s \times I_S$ (W)
 - ⑥ Power consumption in control circuit
 $P_{icc} = V_{cc} \times I_{CC}$ (W)
- I_{ave} ; Average output current (see Fig. 3.5.9.1) (A)
 V_{ONT} ; Drop in the output voltage of the top arm IGBT @ $I = I_{ave}$ (V)
 V_{ONB} ; Drop in the output voltage of the bottom arm IGBT @ $I = I_{ave}$ (V)
 D ; PWM duty
 V_{FDT} ; Forward voltage drop in the FWD of the top arm @ $I = I_{ave}$ (V)
 E_{on} ; Switching loss when the IGBT is turned on @ $I = I_{ave}$ (J/pulse)
 E_{off} ; Switching loss when the IGBT is turned off @ $I = I_{ave}$ (J/pulse)
 f_{PWM} ; PWM frequency (Hz)
 I_{rrT} ; Recovery current of the FWD of the top arm (A)
 t_{rrT} ; Reverse recovery time of the FWD of the top arm (s)
 V_s ; V_s power voltage (V)
 V_{cc} ; V_{cc} power voltage (V)
 I_S ; Current consumption of the high-voltage circuit (A)
 I_{CC} ; Current consumption of the control circuit (A)

(Note) FWD: Free Wheeling Diode

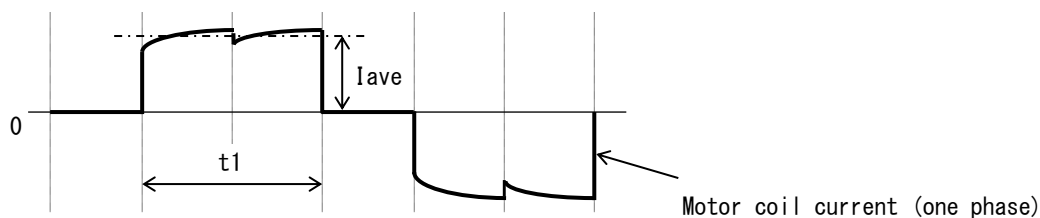

I_{ave} : average motor coil current during the period t_1

FIGURE 3.5.9.1 Current Waveform of the Motor Coil (120-degree Energization)

(2) Calculation of junction temperature

A junction temperature can be calculated by the following equation after measuring the temperature of the IC case (Tc).

$$T_j = T_c + R_{jc} \times P$$

- T_j : Junction temperature (°C)
- T_c : IC case temperature (°C) (actual measurement)
- R_{jc} : Thermal resistance of between junction and IC case (°C/W)
- P : Total IC power consumption (W)

- Measuring method of T_c (SOP26, DIP26, DIP26N)

A thermo-couple is set on the tab of IC to measure the IC case temperature T_c.

After starting to apply a current, wait until the temperature becomes saturated (temperature stops rising). Use a value measured after temperature saturation. The tab is connected to the GL pin as described in Section 3.6.1 (2). Therefore, be careful not to get an electric shock when the potential at the GL pin is floating with respect to earth ground.

- Measuring method of T_c (HSOP36N)

A thermo-couple is set on the center of IC resin (top surface) to measure the IC case temperature T_c.

After starting to apply a current, wait until the temperature becomes saturated (temperature stops rising). Use a value measured after temperature saturation.

3.5.10 Derating

- How much to derate a unit from the maximum rating is an important issue to consider a reliable design. Items to be considered in the stage of system design include the derating of voltage, current, power, load, and electric stresses, along with the derating of temperature, humidity, other environmental conditions, vibration, impact, and other mechanical stresses.
- Table 3.5.10.1 specifies the standard examples of derating to be considered when creating a reliable design. To consider these derating items in the equipment design stage is desirable for achieving reliability. If any item is difficult to be controlled within the standard, another means will be necessary, such as selecting a device having higher maximum ratings. Please consult our sales representative in advance.

TABLE 3.5.10.1 Typical Derating Design Standards

Item	Derating Design Standard (example)	
Junction temperature T _j	110°C maximum	
V _s power supply voltage	ECN30110	210V maximum
	ECN30210	450V maximum

3.5.11 External Parts

Table 3.5.11.1 shows recommended external parts.

TABLE 3.5.11.1 External Parts

Parts	Standard value	Usage	Remarks
C0	1.0μF±10%, 25V	Smooths the internal power supply (VB)	
CV1	1.0μF±10%, 25V	Smooths the Vcc power supply	Note 1
CV2	33nF±10%, 400V (ECN30110) 33nF±10%, 630V (ECN30210)	Smooths the Vs power supply	Note 2
C1, C2	0.22μF±10%, 25V	For charge pump	Note 7
C3, C4, C5	1000pF±10%, 25V	Eliminates Hall signal noise	Note 3
Rs	1Ω±1%, 1W	Sets current limit	Note 4, Note 6
CTR	2200pF±5%, 25V	Sets PWM frequency	Note 5
RTR	11kΩ±5%		
CM	1.0μF±10%, 25V	For motor lock protection	
CF	470pF±10%, 25V	For over-current protection	
RF	2MΩ±10%		

Note 1. As necessary, increase the capacitance and add a zener diode in consideration of noise immunity. Mount each of the parts close to the pins of the IC.

Note 2. As necessary, increase the capacitance and add a zener diode (5W as a guide) in consideration of noise immunity. Mount each of the parts close to the pins of the IC.

Note 3. Adjust the capacitance in accordance with the usage conditions.

Note 4. The current limit set value can be calculated as follows. $I = V_{ref1} / R_s$ (A)

Determine the shunt resistance R_s with reference to the above and Section 4 in the Product Specification.

Note 5. The PWM frequency is approximated by the following equation: $f_{PWM} \approx 0.494 / (CTR \times RTR)$ (Hz)

Please set the maximum frequency of PWM is 20kHz as a guide. When the PWM frequency is set a high frequency, the switching loss is increased. And it increases the temperature of IC. Please confirm the IC temperature with an actual set, and use it in the range of derating.

Note 6. Please shorten the wiring between the resistor R_s and the RS pin, and the wiring between the resistor R_s and the GH pin as much as possible.

Note 7. Attention of parts settings of charge pump circuit

The following attention is necessary when using parts other than those shown in Table 3.5.11.1.

- When the voltage (V_{cp}) between C+ and VS is dropped, the gate voltage of top arm IGBTs is dropped. And then the loss of IC increases. The V_{cp} must not become $V_{cp} < 10V$.
- Capacitor: The V_{cp} is dropped by the internal current dissipation from C+ terminal of IC, when capacity is small. The voltage impressed to the capacitor is almost the same as V_{cc} in operation. Therefore, the withstand voltage of the capacitor requires more than the V_{cc} voltage.

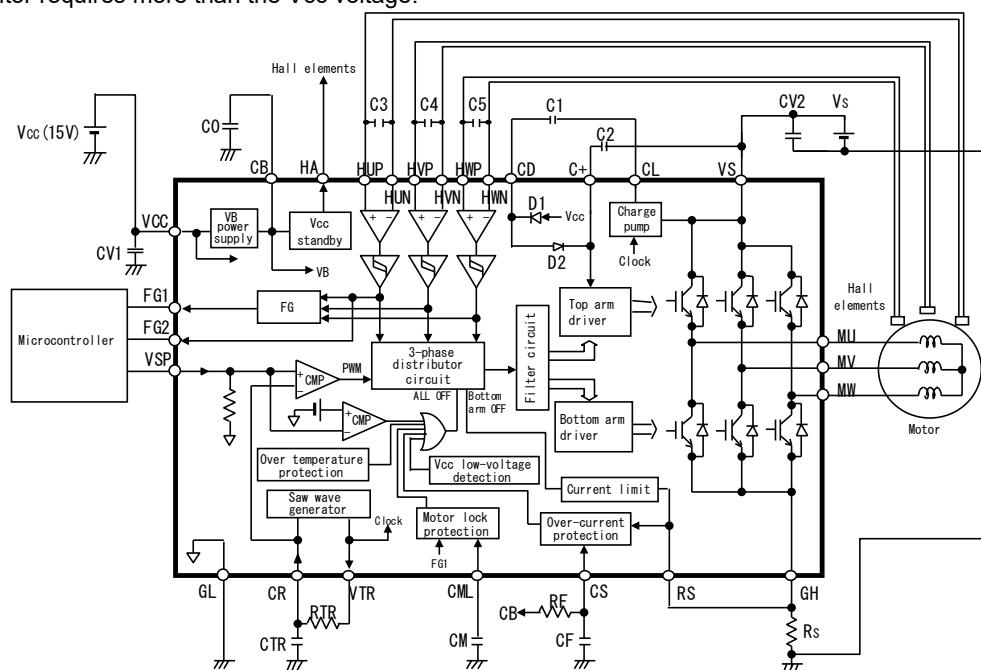

FIGURE 3.5.11.1 Block Diagram and External Parts of IC

3.6 Handling

3.6.1 Mounting

(1) Insulation between pins

High voltages are applied between the pin numbers specified below. Please apply coating resin or molding treatment as necessary.

- SOP26, DIP26, DIP26N : Between pin numbers: 2-3, 4-5, 5-6, 6-7, 7-8
- HSOP36N : Between pin numbers: 25-27, 27-29, 29-31, 31-32, 33-34

(2) Connection of tabs

The tab and the GL pin of the IC are connected in the frame. Regarding the tab, take note of the following points.

(a) SOP26

Leave the tab unconnected or set the tab potential to the same as that of the GL pin

The tab is placed on the IC lower surface (on PCB side). Wiring lines other than GND on the PCB must not touch the tab even if a coating such as solder resist is applied. Please secure sufficient insulation distance particularly between high voltage wiring lines and the tab.

(b) DIP26

Leave the tab unconnected or set the tab potential to the same as that of the GL pin

The tab is placed on the IC upper surface. If it is required to insulate between the IC tab and the housing, please insert an insulation sheet or something similar between them. If the insulation between the tab and the housing is insufficient, the IC will not be able to withstand an isolation withstand voltage test in which a high voltage is applied between the housing and the GND.

(c) DIP26N

The tab is placed on the IC upper surface. If a heat sink is attached to the tab by screwing, set the heat sink potential to the same as that of the GL pin. If a heat sink is not attached to the tab and it is required to insulate between the IC tab and the housing, please insert an insulation sheet or something similar between them. If the insulation between the tab and the housing is insufficient, the IC will not be able to withstand an isolation withstand voltage test in which a high voltage is applied between the housing and the GND.

(3) Lead pin reliability

When using DIP26N with the heat sink attached, the lead pin can be destroyed by vibration or impact depending on use conditions because a load is applied to the lead pin. Please sufficiently assess the IC by a vibration test after mounting the IC. In particular, please note that space between the IC body (resin part) and PCB increases a load.

(4) Tab suspension

Figure 3.6.1.1 shows a side view of the IC.

There are parts called "tab suspension" on both side surfaces of the IC. These tab suspensions are connected to the same potential as the GL pin. When the high voltage wire or/and parts are laid out close to the tab suspensions, insulate them with coating, mold, or other treatment.

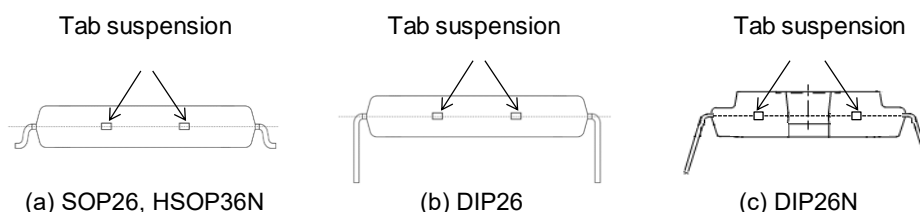

FIGURE 3.6.1.1 Side Views of IC

(5) Coating resin

The influence of coating resin on semiconductor devices (thermal stress, mechanical stress and other stress) depends on PCB size, mounted parts, etc. to be used. When selecting a coating resin, consult with your PCB manufacturer and resin manufacturer.

(6) Soldering conditions

(a) Soldering conditions for SOP26, HSOP36N

The recommended reflow soldering condition is shown in Fig. 3.6.1.2.

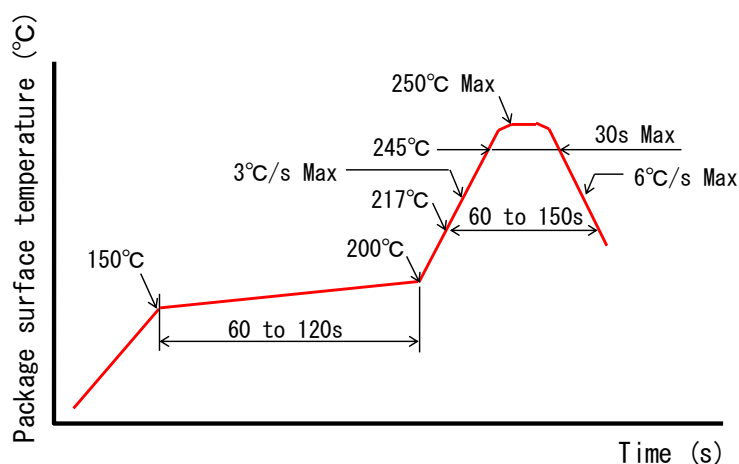

FIGURE 3.6.1.2 Recommended Conditions for Infrared Reflow or Air Reflow

(b, c) Soldering conditions for DIP26, DIP26N

The peak temperature of flow soldering* must be 260°C or less, and the dip time must be within 10 seconds. High stress by mounting, such as long time thermal stress by preheating, mechanical stress, etc., can lead to degradation or destruction. Make sure that your mounting method does not cause problem as a system.

If attaching a heat sink, do not solder to the tab. The solder on the tab impairs the tab flatness, which causes poor contact with the heat sink mounting surface. As a result, the heat dissipation may decrease.

※ Flow soldering: Only pins enter a solder bath, while the resin or tab does not.

(7) Solder joint reliability

Reliability of solder joints is influenced by soldering conditions, PCB material and foot patterns. Perform adequate evaluations on thermal cycle tests, heat shock tests, and other tests after mounting the IC on a PCB. Special care should be taken if SOP26 or HSOP36N is mounted on a PCB having a high coefficient of thermal expansion (such as CEM-3) because the solder joint life could be shortened.

3.6.2 Precautions for Mounting Heat Sink

To radiate heat of the IC, attaching a heat sink to the tab side is effective. When attaching a heat sink, please select DIP26N. Then, it is recommended to attach a heat sink to the IC body (resin part) by screwing. If other methods are used such as attaching with a clip or attaching to PCB by screwing, problems can be caused such as variation of adhesion strength between a heat sink and the IC or deterioration in reliability of attachment points. For these reasons, please select and adopt a method at the user's own responsibility. When attaching a heat sink to DIP26N by screwing, set the heat sink potential to the same as that of the GL pin and note the following points.

(1) Heat sink

Inappropriate heat sinks will hinder heat radiation. In addition, adding unnecessary stress will cause characteristic degradation or resin cracks.

Observe the following points regarding heat sinks:

- To avoid a heat sink causing convex or concave warping, keep the warp and twisting between screw holes less than 0.05 mm (Fig. 3.6.2.1).
- For aluminum, copper, and iron boards, make sure there is no press tension, and always bevel the screw holes.
- A contact surface with the IC must be ground flat. (Average surface roughness **Ra** shall be 3.2 to 6.3 μm .)
- Prevent and remove any shaved particles between the IC tab and the heat sink.
- Make sure the screw hole gaps match those of the IC (typ. 29.5mm). If they are too wide or too narrow, resin cracks may occur.

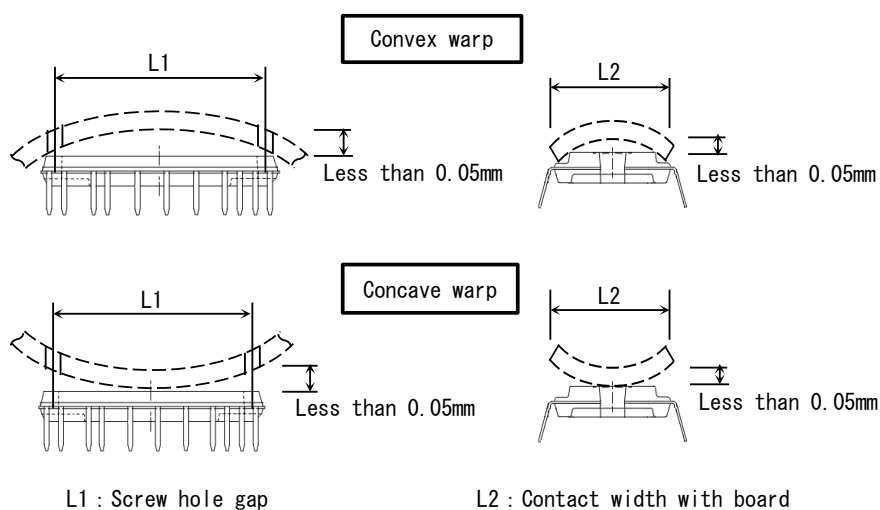

FIGURE 3.6.2.1 Heat Sink Warping

(2) Screws

The screws that attach the heat sink to the device are generally classified into small screws and tapping screws. Observe the following precautions when using these types of screws:

- (a) Use small bind and truss screws that have heads which meet JIS-B1101 standards.
- (b) Avoid using countersink screws, which add abnormal stress to devices (Fig. 3.6.2.2).
- (c) The use of tapping screws increases tightening torque. Therefore, there is a possibility that desired contact resistance cannot be obtained. When using tapping screws, prevent tightening torque from becoming too large. For tightening torque, see Section 3.6.2 (3).
- (d) When using a tapping screw, use one that is thinner than the IC attachment hole diameter. If thicker screws are used, tapping the IC attachment holes or heat sinks can promote failures.

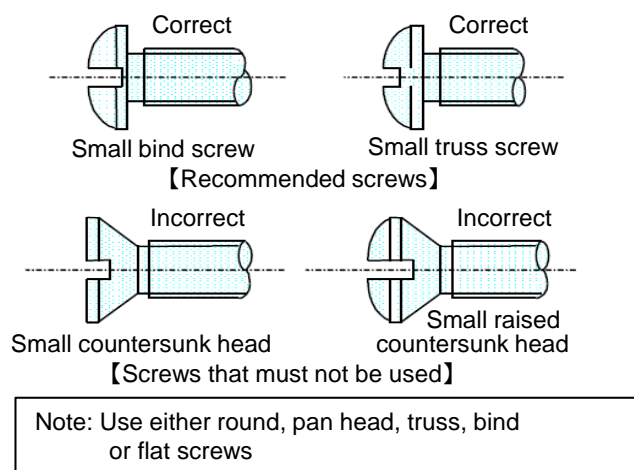

FIGURE 3.6.2.2 Recommended and Prohibited Screws

(3) Tightening method

Insufficient tightening torque invites an increase in heat resistance, and excessive torque invites such failures as warping of the device, cracking of resin, die destruction, and connector lead breakage. Please use the tightening torque value 0.39 to 0.59N·m (4 to 6 kg·cm). (Attached screw: M3)

Use a manual torque screwdriver or electric screwdriver for tightening. Do not use an impact driver. When using an electric screwdriver, the maximum rotation speed at the time of tightening must be 700 rpm. If tightened at higher speeds than 700 rpm, the IC is overstressed, which may result in resin cracking.

Tightening sequence is shown as Fig 3.6.2.3.

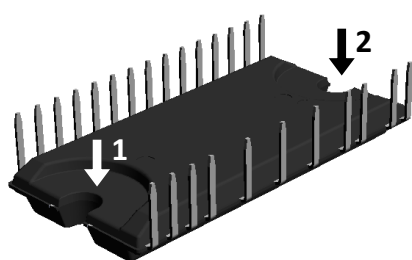

- (a) Tightening sequence
 Temporary tightening : 1→2
 Final tightening : 1→2
 Torque for temporary tightening should be 20 - 30 % of maximum torque.
- (b) Flat washer or spring washer should be put in.
 IC might get crack without the washer.

FIGURE 3.6.2.3 Typical Tightening Sequence

(4) Silicone grease

Apply a thin layer (100um or less) of silicon grease evenly over the contact surface between the IC and the heat sink to maximize heat conduction. Applying more silicon grease than necessary may reduce heat dissipation and overstress the IC, which may result in resin cracking. Moreover, avoid high-viscosity (hard) greases to prevent resin from cracking.

Example of silicone grease is shown in Table 3.6.2.1. We recommend the silicone grease shown below or comparable one.

TABLE 3.6.2.1 Recommended Silicone Grease

No.	Product name	Manufacturer
1	G-747	Shin-Etsu Chemical Co., Ltd

4. Failure Examples (Assumptions)

4.1 Electrical Destruction of VSP Pin Caused by External Surge

- Cause : An external surge enters the IC on the Vsp line of the motor.
- Phenomenon : The Vsp signal is not transmitted into the IC, and the motor does not rotate.
- Countermeasure : Insert series resistance so that the external surge does not directly enter the IC. If a capacitor is also added, it becomes more effective.

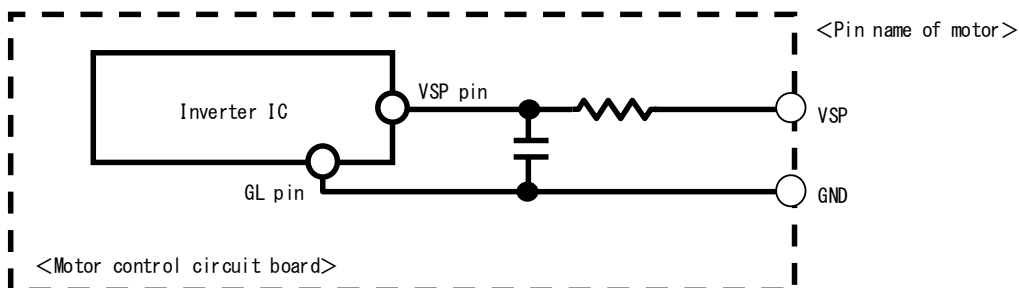

FIGURE 4.1.1 Example of Configuration for External Parts of VSP

4.2 Electrical Destruction of FG1 and FG2 Pins Caused by External Surge

- Cause :An external surge directly enters the IC on the FG line of the motor.
- Phenomenon :The FG signal of the IC is not outputted.
- Countermeasure :Use the buffer circuit using the transistor on the motor control circuit board so that the external surge does not directly enter the IC.

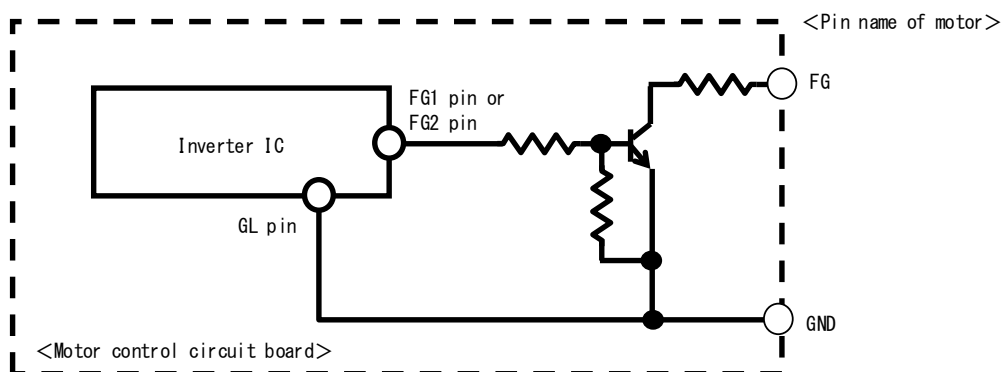

FIGURE 4.2.1 Example of Configuration for External Parts of FG1, FG2

4.3 Inverter IC Destruction by External Surge Inputted to Vs and Vcc (15V) Lines (Case 1)

- Cause : An external surge enters the IC on the Vs and Vcc lines of the motor. Because the capacitance of the bypass capacitor for surge suppression was small, the surge could not be sufficiently suppressed.
- Phenomenon : The motor does not rotate due to the over voltage destruction of the IC.
- Countermeasure : Use the bypass capacitor for surge suppression; its capacity should be enough to suppress surges.

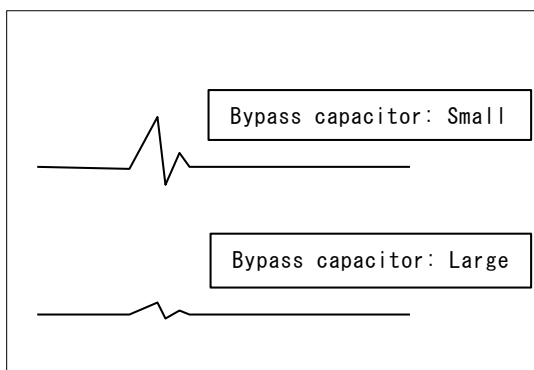

FIGURE 4.3.1 Example of Surge Waveforms for Different Bypass Capacitors

4.4 Inverter IC Destruction by External Surge Inputted to Vs and Vcc (15V) Lines (Case 2)

- Cause : An external surge enters the IC on the Vs and Vcc lines of the motor. Because the external parts for surge suppression were positioned far from the IC on the circuit board, the surge could not be sufficiently suppressed.
- Phenomenon : The motor does not rotate due to the over voltage destruction of the IC.
- Countermeasure : The bypass capacitor and Zener diode for surge suppression should be mounted close to the IC.

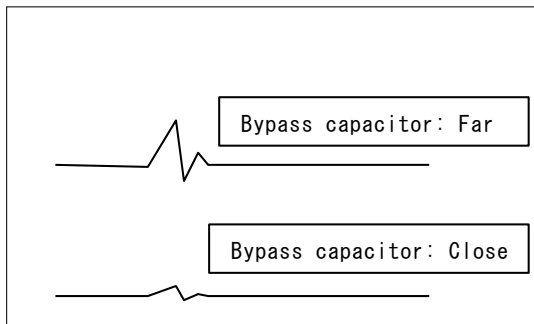

FIGURE 4.4.1 Example of Surge Waveform for Different Bypass Capacitor Locations on Board

4.5 Inverter IC Destruction by External Surge Inputted to Vs and Vcc (15V) Line (Case 3)

- Cause : When a power supply line is in an open state due to the connector contact failure of Vs or Vcc (15V) line or the like, the supply power is turned on. Then, when the power supply line goes into a closed state, a surge occurs and enters the IC.
- Phenomenon : The motor does not rotate due to the over-voltage destruction of the IC.
- Countermeasure: The Zener diode for surge suppression should be mounted close to the IC.

4.6 Inverter IC Destruction by External Surge Inputted to Vs and Vcc (15V) Line (Case 4)

- Cause : An external surge enters the IC on the Vs and Vcc lines of the motor. Because the Zener voltage of the surge suppressor diode is higher than the maximum rating voltage of the IC, it does not protect the IC.
- Phenomenon : The motor does not rotate due to the over-voltage destruction of the IC.
- Countermeasure : Use a surge suppressor diode with Zener voltage, which is lower than the maximum rating voltage of the IC. The larger the rating capacity of the Zener diode, the more effectively the surge suppressor works.

4.7 Inverter IC Destruction by External Surge Inputted to Vcc (15V) Line

- Cause : Pulsed noise of a voltage that is lower than the operating voltage of the Vcc low-voltage detection (LVSDON) enters the Vcc (15V) line. In this case, the IC repeats split-second LVSD operation. Then the IC has the possibility of overheat breakage.
- Phenomenon : The motor does not rotate due to the destruction of the IC.
- Countermeasure: ①Remove the noise that enters the motor Vcc line by reviewing the power supply circuit (inductance of power cable or the like).
②Connect a capacitor having sufficient capacitance close to the VCC pin and GL pin of the IC to absorb noise.

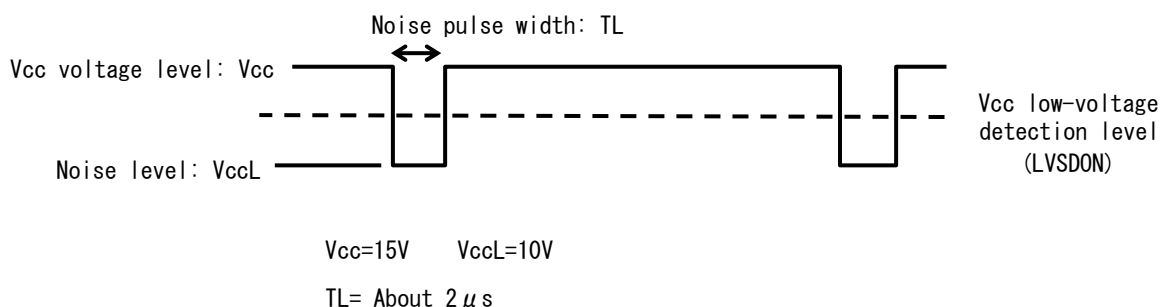

FIGURE 4.7.1 Example of Pulsed Noise on Vcc Line

4.8 Inverter IC Destruction by Vcc (15V) Line Noise

- Cause : Surge voltage that exceeds the maximum rating for the IC enters the VCC pin.
- Phenomenon : The motor does not rotate due to the over-voltage destruction of the IC.
- Countermeasure:
 - ① Mount a bypass capacitor C1 near the pin of the IC. Use a capacitor that has excellent frequency characteristics, such as a ceramic capacitor. As a guide, a capacitor of around 1μF is recommended.
 - ② It is more effective to mount a surge suppression device, such as bypass capacitor C2 shown in Fig. 4.8.1, close to the connector of a motor control circuit board.

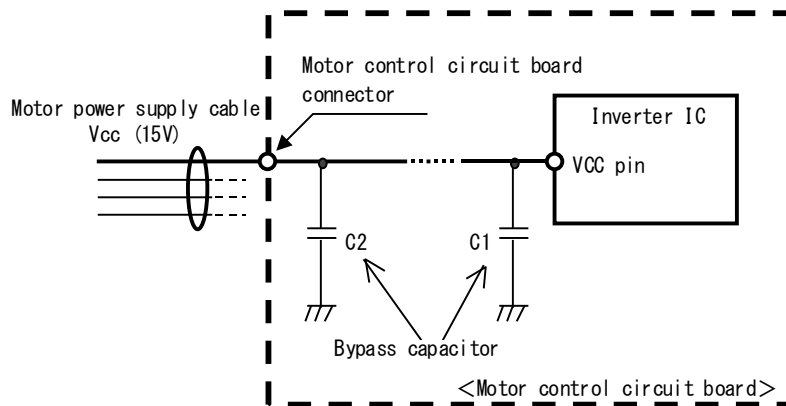

FIGURE 4.8.1 Example of Mounted Surge Suppression Devices

4.9 Inverter IC Destruction by Inspection Machine Relay Noise

- Cause : A mechanical relay for on-off control of the electric connection between the IC and an inspection machine generates a surge that enters the IC.
- Phenomenon : The motor does not rotate due to the over-voltage destruction of the IC.
- Countermeasure : Use a mercury relay, etc. Confirm a surge is not generated when the relay is on-off.

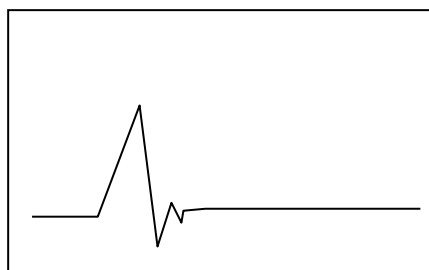

FIGURE 4.9.1 Example of Surge Waveform When Mechanical Relay is Used

4.10 Motor Failure (Missing Phase Output)

- Cause : The motor with missing phase has been out on the market.
- Phenomenon : The motor might start depending on the rotor position when starting even if the motor has missing phase output. Therefore, the missing phase output of motor cannot be detected by the motor rotation test.
- Countermeasure: Monitor the motor current or torque pulsations in order to detect the missing phase output of motor.

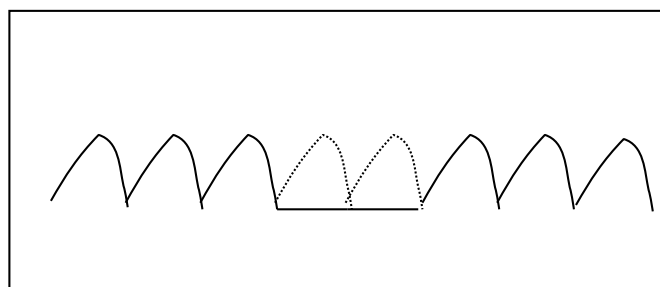

FIGURE 4.10.1 Example of Motor Current Waveform in Phase Missing Condition

5. Precautions for Use

5.1 Countermeasures against Electrostatic Discharge (ESD)

- (a) Customers need to take precautions to protect ICs from electrostatic discharge (ESD). The material of the container or any other device used to carry ICs should be free from ESD, which can be caused by vibration during transportation. Use of electrically conductive containers is recommended as an effective countermeasure.
- (b) Everything that touches ICs, such as the work platform, machine, measuring equipment, and test equipment, should be grounded.
- (c) Workers should be high-impedance grounded (100kΩ to 1MΩ) while working with ICs, to avoid damaging the ICs by ESD.
- (d) Friction with other materials, such as high polymers, should be avoided.
- (e) When carrying a PCB with a mounted IC, ensure that the electric potential is maintained at a constant level using the short-circuit terminals and that there is no vibration or friction.
- (f) The humidity at an assembly line where ICs are mounted on circuit boards should be kept around 45 to 75 percent using humidifiers or such. If the humidity cannot be controlled effectively, using ionized air blowers (ionizers) is effective.

5.2 Storage Conditions (applied to: ECN30110F, ECN30110S, ECN30210F, ECN30210S)

- (1) Before opening the moisture prevention bag (aluminum laminate bag)

Temperature: 5°C to 35°C
 Humidity: 85%RH or lower
 Period: less than 2 years

- (2) After opening the moisture prevention bag (aluminum laminate bag)

Temperature: 5°C to 30°C
 Humidity: 70%RH or lower
 Period: less than 1 week

- (3) Temporal storage after opening the moisture prevention bag

When ICs are stored temporarily after opening the bag they should be returned into the bag with desiccant within 10 minutes. Then, the open side of the bag should be folded under twice, and closed with adhesive tape. And it should be kept in the following conditions.

Temperature: 5°C to 35°C
 Humidity: 85%RH or lower
 Period: less than 1 month

※ When the period of (1) to (3) is expected to expire, it is recommended to store ICs in a drying furnace (30%RH or lower) at ordinary temperature.

- (4) Baking process

When the period of (1) to (3) has expired, ICs should be baked in accordance with the following conditions. (However, when ICs are stored in a drying furnace (30%RH or lower) at ordinary temperature, there is no need to bake.)

Do not bake the tape and the reel of the taping package because they are not heat resistant.

Transfer ICs to a heat resistant container prior to baking.

Temperature: 125±5°C
 Period: 16 to 24 hours

5.3 Maximum Ratings

Regardless of changes in external conditions during use of our IC, the “maximum ratings” should never be exceeded when designing electronic circuits that employ our IC. If maximum ratings are exceeded, our IC may be damaged or destroyed. In no event shall our company be liable for any failure in our IC or any secondary damage resulting from use at a value exceeding the maximum ratings.

5.4 Derating Design

Continuous high-load operation (high temperatures, high voltages, large currents) should be avoided and derating design should be applied, even within the ranges of the maximum ratings, to ensure reliability.

5.5 Safe Design

Our IC may fail due to accidents or unexpected surge voltages. Accordingly, adopt safe design features, such as redundancy and measures to prevent misuse, in order to avoid extensive damage in the event of a failure.

5.6 Application

If our IC is applied to the following uses where high reliability is required, obtain the document of permission from our company in advance.

- Automobile, Train, Vessel, etc.

Do not apply our IC to the following uses where extremely high reliability is required.

- Nuclear power control system, Aerospace instrument, Life-support-related medical equipment, etc.

6. Notes Regarding this Document

- (1) All information included in this document such as product data, diagrams, charts, algorithms, and application circuit examples, is current as of the date this document is issued. Such information, specifications of products, etc. are subject to change without prior notice. Before purchasing or using any of our products listed in this document, please confirm the latest product information with our sales office.
- (2) Our company shall not be held liable in any way for damages and infringement of patent rights, copyright or other intellectual property rights arising from or related to the use of the information, products, and circuits in this document.
- (3) No license is granted by this document of any patents, copyright or other intellectual property rights of any third party or of our company.
- (4) This document may not be reprinted, reproduced or duplicated, in any form, in whole or in part without the express written permission of our company.
- (5) You shall not use our products (technologies) described in this document and any other products (technologies) manufactured or developed by using them (hereinafter called "END Products") or supply our products (technologies) and END Products for the purpose of disturbing international peace and safety, including (i) the design, development, production, stockpiling or any use of weapons of mass destruction such as nuclear, chemical or biological weapons or missiles, (ii) the other military activities, or (iii) any use supporting these activities. You shall not sell, export, dispose of, license, rent, transfer, disclose or otherwise provide our products (technologies) and END Products to any third party whether directly or indirectly with knowledge or reason to know that the third party or any other party will engage in the activities described above.
When exporting, re-export transshipping or otherwise transferring our products (technologies) and END Products, all necessary procedures are to be taken in accordance with Foreign Exchange and Foreign Trade Act (Foreign Exchange Act) of Japan, Export Administration Regulations (EAR) of US, and any other applicable export control laws and regulations promulgated and administered by the governments of the countries asserting jurisdictions over the parties or transaction.
- (6) Our company has taken reasonable care in compiling the information included in this document, but our company assumes no liability whatsoever for any damage incurred as a result of errors or omissions in the information included in this document.
- (7) Please contact our sales office if you have any questions regarding the information in this document or any other inquiries.