

# 3-Phase BLDC Motor Driver IC

---

## ECN30210S Product Specification

---

Rev. 4

### 1. Product Description

#### 1.1 Features

- (1) Maximum Ratings: 600VDC/1.5A, suitable for the system from 200VAC to 240VAC
- (2) Drives a motor using high voltage PWM (Pulse Width Modulation) control, increasing efficiency
- (3) Variable speed control by an analog speed command signal (VSP signal)
- (4) Six IGBTs, six FWDs (Free-Wheeling Diodes), drivers for IGBTs, protection circuits, etc. integrated into a single chip, resulting in space reduction
- (5) Drives a motor using a high voltage DC power supply and a low voltage DC power supply (15V)

#### 1.2 Functions

- (1) Hall elements applicable (Hall amplifiers are embedded)
- (2) Power on/off sequence-free (condition: output pin current is less than 1A)
- (3) Charge pump circuit (built-in high voltage diodes for charge pump)
- (4) FG (Frequency Generator) signal outputs for motor rotational speed monitor (three pulses and one pulse)
- (5) All IGBT shutoff function
- (6) Current limit (detects at 0.5V)
- (7) Over-current protection (detects at 1.0V)
- (8) Vcc low-voltage detection
- (9) Over temperature protection
- (10) Motor lock protection
- (11) PWM circuit (enable 20kHz PWM operation)
- (12) Three-phase distributor circuit
- (13) Vcc standby function

### 1.3 Block Diagram

The ECN30210S is shown inside the bold line.

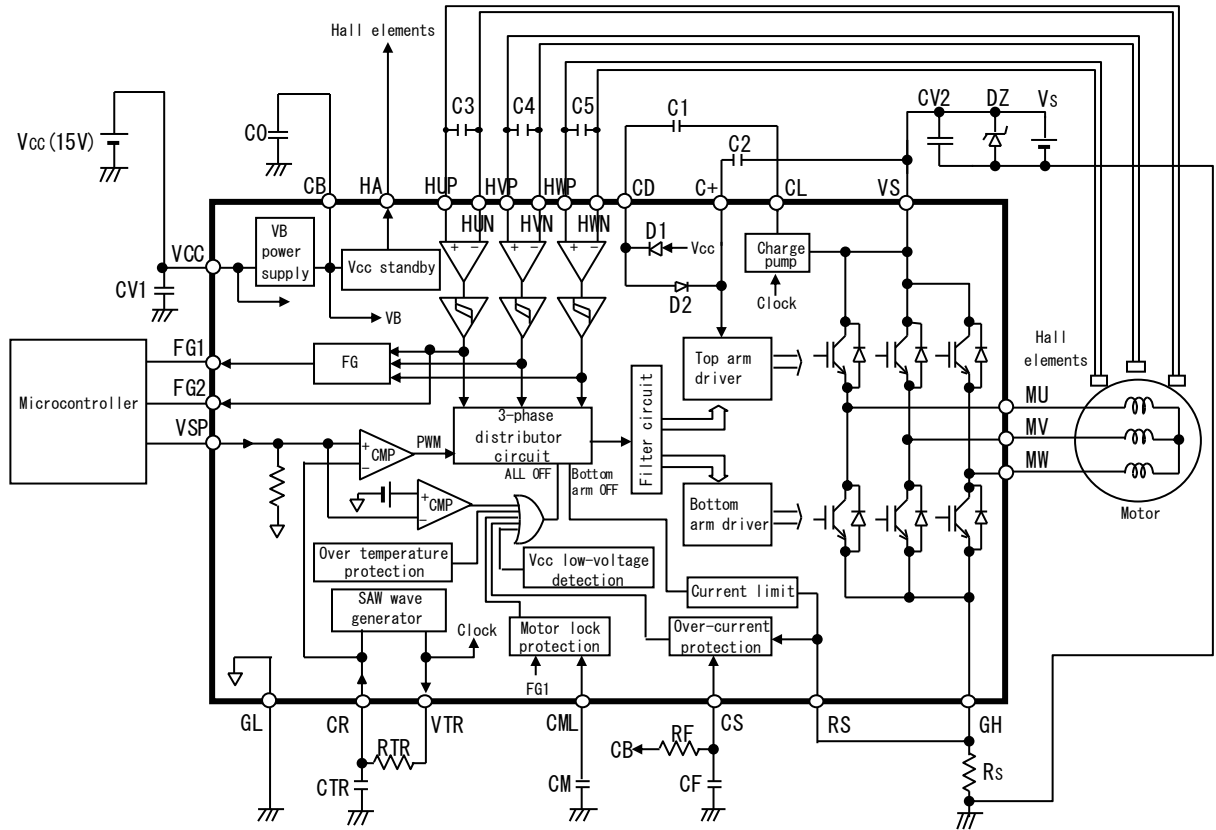

**FIGURE 1.3.1 Block Diagram**

### 1.4 Package

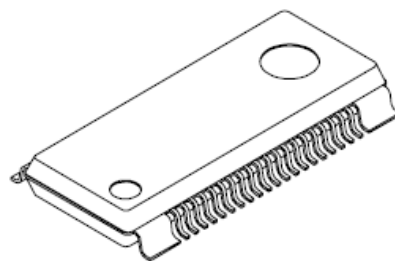

(Package: HSOP-36N)

**FIGURE 1.4.1 Package of ECN30210S**

## 2. Specification

### 2.1 Maximum Ratings

**TABLE 2.1.1 Maximum Ratings**

Condition: Ta=25°C

No.	Item	Symbol	Pin	Rating	Unit	Condition
1	Output device withstand voltage	VSM	VS, CL, CD, MU, MV, MW	600	V	
2	Vcc power supply voltage	VCC	VCC	18	V	
3	Voltage between C+ and VS	VCPM	C+, VS	18	V	
4	Input voltage	VIN	VSP, RS, HUP, HUN, HVP, HVN, HWP, HWN	-0.5 to VB+0.5	V	
5	Output current	Pulse	IP	MU, MV, MW	A	Note 1
6		DC				
7	VB supply output current	IBMAX	CB, HA	50	mA	Note 2
8	Junction operating temperature	Tjop	—	-40 to +135	°C	Note 3
9	Storage temperature	Tstg	—	-40 to +150	°C	

Note 1: Output IGBTs can handle this peak current.

Note 2: "IBMAX" represents the sum of output currents at the CB pin and the HA pin.

Note 3: Thermal resistance

Between junction and case: Rjc = 3°C/W (Reference value)

2.2 Electrical Characteristics

**TABLE 2.2.1 Electrical Characteristics (1/2)** Suffix (T: Top arm, B: Bottom arm) Condition: Ta=25°C

No.	Item	Symbol	Pin	Min.	Typ.	Max.	Unit	Condition		
1	Standby current	ISH	VS	—	0.1	0.4	mA	VSP=0V, VS=325V, VCC=15V		
2		ICC	VCC	—	4	10	mA	VSP=0V, VCC=15V, IB=0A Note 7		
3	IGBT collector-emitter saturation voltage	VONT	MU,	—	2.0	3.0	V	I=0.35A, VCC=15V		
4		VONB	MV,	—	2.0	3.0	V			
5	Free-wheeling diode forward voltage	VFDT	MW	—	1.6	2.8	V	I=0.35A		
6		VFDB		—	1.6	2.8	V			
7	VTR output resistance	RVTR	VTR	—	200	400	Ω	IVTR=±1mA, VCC=15V		
8	SAW wave	High/Low level	CR	VSAWH	4.9	5.4	5.9	V	VCC=15V	
9				VSAWL	1.7	2.1	2.4	V		
10		Amplitude		VSAWW	2.8	3.3	3.8	V		VCC=15V Note 1
11	Current limit	Reference voltage	RS	Vref1	0.45	0.50	0.55	V	VCC=15V	
12		Delay time		Tref1	1.2	2.0	4.5	μs		
13	Over-current protection	Reference voltage	RS,	Vref2	0.8	1.0	1.2	V	VCC=15V	
14		Delay time								CS
15		Recovery time	Trs	—	1.0	2.0	ms	VCC=15V, CF=470pF RF=2MΩ		
16	RS input current	IILRS	RS	-100	—	—	μA	VCC=15V, RS=0V Note 5		
17	Hall signal input	Minimum differential voltage	HUP, HUN, HVP, HVN, HWP, HWN	VHOS	60	—	—	mVp-p	VCC=15V Note 2	
18		Current		IH	—	—	2	μA		
19		Common mode voltage range		VHCM	3	—	6	V		
20		Hysteresis		VHHYS	20	40	60	mV		
21		Voltage L→H		VHLH	-5	20	45	mV		
22		Voltage H→L		VHHL	-45	-20	5	mV		
23	VSP input	Current	VSP	IVSPH	5	—	100	μA	VSP=5.0V, VCC=15V Pull-down resistor Note 3	
24		Offset voltage		SPCOMOF	-40	60	160	mV		VCC=15V Voltage from CR pin
25		All off operating voltage		Voff	0.85	1.23	1.60	V		VCC=15V
26	VB supply output	Voltage	CB	VB	6.8	7.5	8.2	V	VCC=15V, IB=0A Note 7	
27		Current		IB	—	—	45	mA		VCC=15V Note 7
28	HA output resistance	RHA	HA	—	20	40	Ω	VCC=15V, IHA=10mA		
29	FG1, FG2 output resistance	RFGP	FG1, FG2	—	0.9	3.0	kΩ	IFG=1mA, VCC=15V Note 4		
30		RFGN		—	0.4	1.5	kΩ		IFG=-1mA, VCC=15V Note 4	
31	Vcc low-voltage detection	Operating voltage	VCC,	LVSDON	11.0	12.0	12.9	V		
32		Recovery voltage		LVSDOFF	MU, MV, MW	11.1	12.5	13.0		V
33	Minimum pulse width (bottom arms)	TMINB	MU, MV, MW	0.8	—	—	μs	VCC=15V Note 6		

**TABLE 2.2.1 Electrical Characteristics (2/2)** Suffix (T: Top arm, B: Bottom arm) Condition: Ta=25°C

No.	Item		Symbol	Pin	Min.	Typ.	Max.	Unit	Condition
34	Charge pump diode forward voltage		VFDCP	VCC, CD, C+	—	0.8	1.4	V	I=1mA
35	Over temperature protection	Operating temperature	TSDON	MU, MV, MW	140	170	195	°C	VCC=15V
36		Recovery temperature	TSDOFF		115	145	170	°C	
37	Motor lock protection	Operating time	TMLON	CML	0.6	2.0	3.0	ms	VCC=15V, CM=1000pF
38		Recovery time	TMLOFF		5	12	20	ms	

Note 1: The amplitude of SAW wave (i.e., VSAWW) is determined by the following equation.

$$VSAWW = VSAWH - VSAWL (V)$$

Note 2: The equivalent circuit is shown in FIGURE 2.2.1.

Note 3: Internal pull-down resistor is typically 240kΩ. The equivalent circuit is shown in FIGURE 2.2.2.

Note 4: The equivalent circuit is shown in FIGURE 2.2.3.

Note 5: Internal pull-up resistor is typically 200kΩ. The equivalent circuit is shown in FIGURE 2.2.4.

Note 6: The minimum pulse width to pass the filter circuit.

Note 7: "IB" represents the sum of output currents at the CB pin and the HA pin.

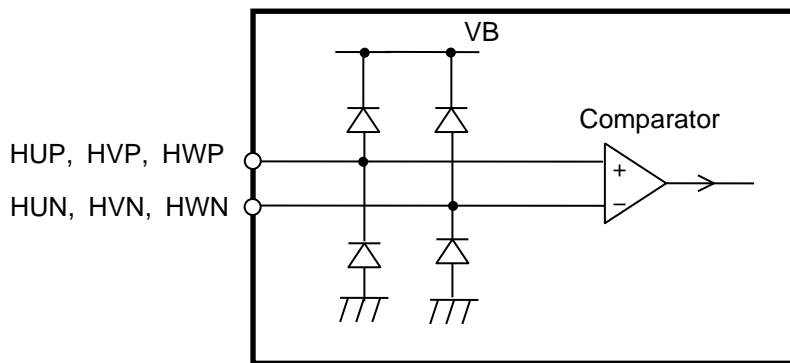

FIGURE 2.2.1 Equivalent Circuit Around Hall Signal Pins

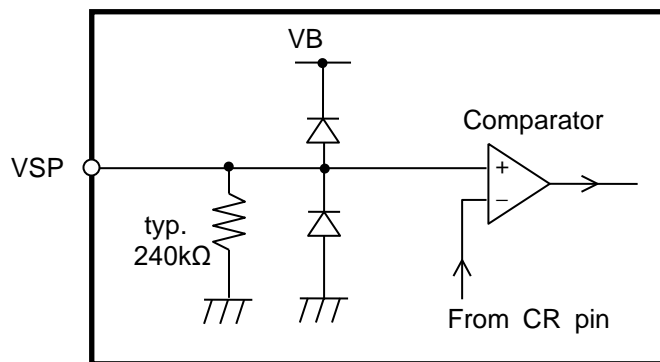

FIGURE 2.2.2 Equivalent Circuit Around VSP Pin

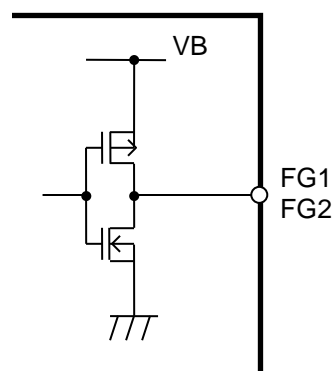

FIGURE 2.2.3 Equivalent Circuit Around FG1, FG2 Pins

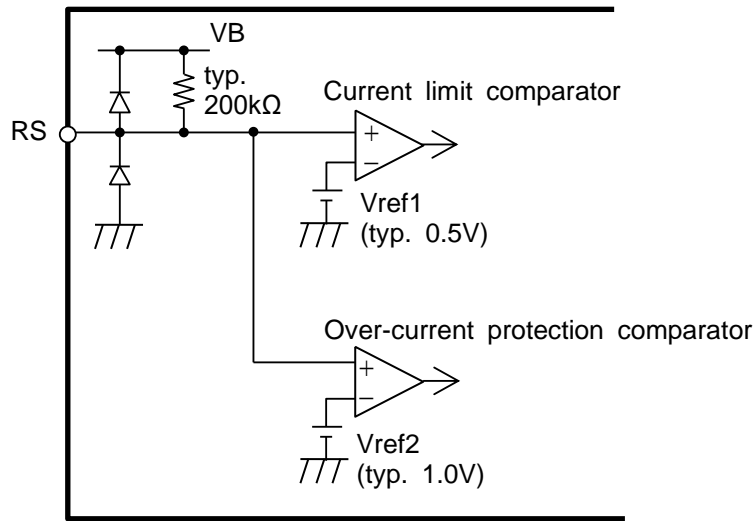

FIGURE 2.2.4 Equivalent Circuit Around RS Pin

2.3 Operating Condition

TABLE 2.3.1 Operating Condition

No.	Item	Symbol	Pin	Min.	Typ.	Max.	Unit
1	Supply voltage	VSop	VS	15	325	450	V
2		VCCop	VCC	13.5	15.0	16.5	V

2.4 Functions and Operations

2.4.1 Truth Table

**TABLE 2.4.1.1 Truth Table**

Mode	Hall signal input			Phase-U		Phase-V		Phase-W		FG1 output	FG2 output
	HU	HV	HW	Top arm	Bottom arm	Top arm	Bottom arm	Top arm	Bottom arm		
(1)	H	L	H	OFF	ON	ON	OFF	OFF	OFF	H	H
(2)	H	L	L	OFF	ON	OFF	OFF	ON	OFF	L	H
(3)	H	H	L	OFF	OFF	OFF	ON	ON	OFF	H	H
(4)	L	H	L	ON	OFF	OFF	ON	OFF	OFF	L	L
(5)	L	H	H	ON	OFF	OFF	OFF	OFF	ON	H	L
(6)	L	L	H	OFF	OFF	ON	OFF	OFF	ON	L	L
—	L	L	L	OFF	OFF	OFF	OFF	OFF	OFF	L	L
—	H	H	H	OFF	OFF	OFF	OFF	OFF	OFF	H	H

Note: Inputs H: Input voltage between H\*P and H\*N > VHLH

Inputs L: Input voltage between H\*P and H\*N < VHHL

2.4.2 Timing Chart

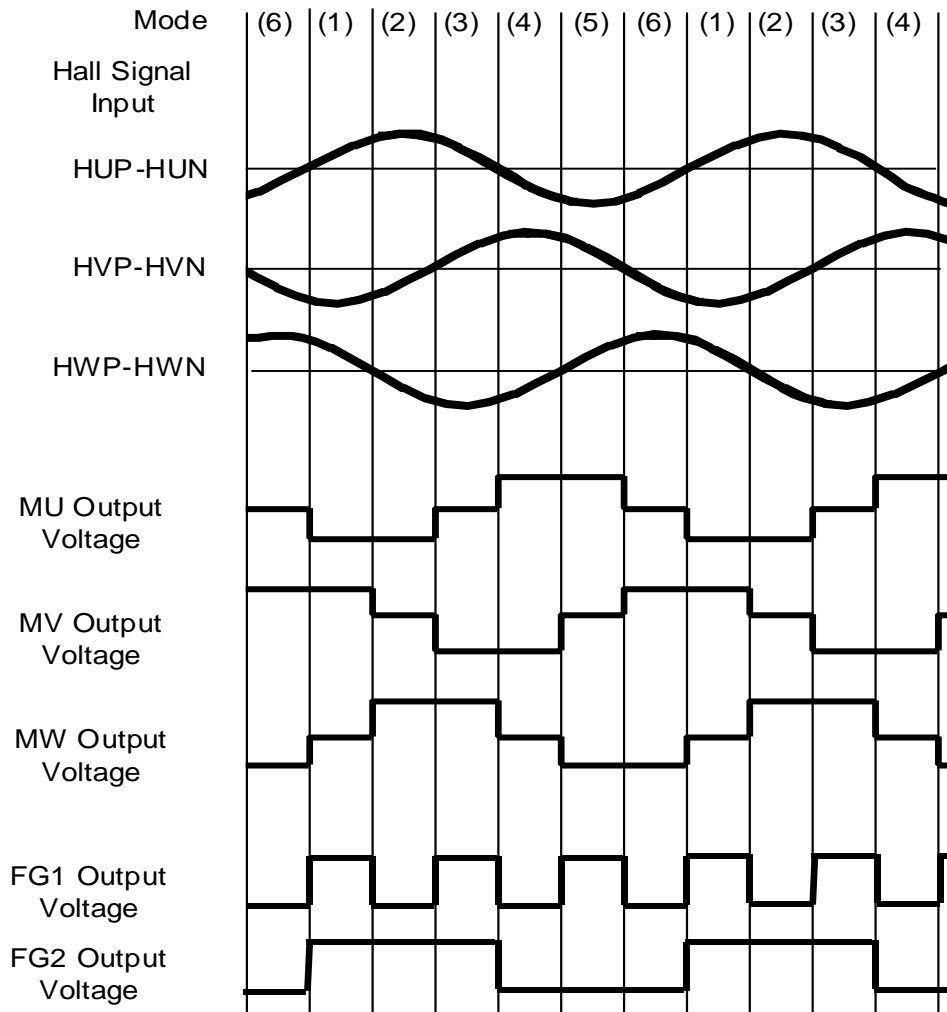

**FIGURE 2.4.2.1 Timing Chart**



2.4.3 PWM Operation

The PWM signal is generated by comparing the input voltage at the VSP pin with an internal SAW wave voltage (available at the CR pin). The relation between VSP input voltage and PWM duty is shown in FIGURE 2.4.3.1. The PWM duty represents the duty of IGBT gate drive signals. The voltages at output pins (MU, MV, MW) may be different from the figure depending on conditions. The PWM is operated by bottom arms.

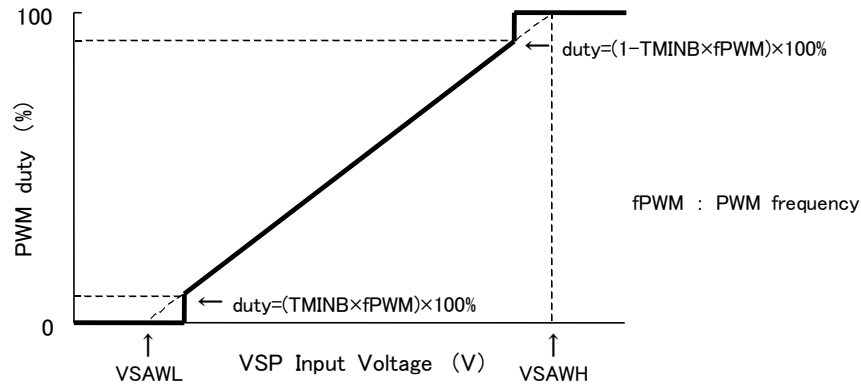

FIGURE 2.4.3.1 Relation between VSP Input Voltage and PWM Duty

2.4.4 Current Limit

This IC detects current using an external shunt resistor  $R_s$ . When the voltage at the shunt resistor  $R_s$  exceeds the current limit reference voltage ( $V_{ref1}$ , typ. 0.5V), all bottom arm IGBTs are turned off. This off state is automatically reset once per internal CLOCK period (available at VTR pin).

2.4.5 Over-current Protection

When the voltage at the shunt resistor  $R_s$  exceeds the over-current protection reference voltage ( $V_{ref2}$ , typ. 1.0V), all IGBTs (top and bottom arms) are turned off. When the over-current protection recovery time ( $T_{rs}$ , typ. 1ms) passes, the IC returns to the state in which the IGBTs operate depending on input signals.

When this function is not used, connect the CS pin to the CB pin.

When the IGBTs of the top and bottom arms are all turned off by operation of this protection or other function during motor driving, the power supply voltage may rise as a result of a regenerative current flow. The power supply voltage must not exceed the maximum rating (600V).

2.4.6 Vcc Low-voltage Detection

When  $V_{cc}$  voltage drops below the operating voltage of the  $V_{cc}$  low-voltage detection (LVSDON), all IGBTs (top and bottom arms) are turned off. When  $V_{cc}$  voltage goes up above the recovery voltage of the  $V_{cc}$  low-voltage detection (LVSDOFF), the IC returns to the state in which the IGBTs operate depending on input signals.

2.4.7 All IGBT Shutoff Function

When the input voltage at the VSP pin drops below VSAWL (typ. 2.1V), the IC stops the motor drive.

When the input voltage at the VSP pin drops further from VSAWL and becomes below  $V_{off}$  (typ. 1.23V), the IGBTs (top and bottom arms) are all shut off to reduce current consumption within the IC. The state of the output IGBTs with regard to the VSP input voltage is shown in TABLE 2.4.7.1.

TABLE 2.4.7.1 IGBT Operation to VSP Input Voltage

VSP Input Voltage	Motor drive state	Top Arm IGBTs	Bottom Arm IGBTs
$0V \leq VSP < V_{off}$	Stop	All OFF	All OFF
$V_{off} \leq VSP < VSAWL$		Based on TABLE 2.4.1.1	All OFF
$VSAWL \leq VSP$	Drive	Based on TABLE 2.4.1.1	Based on TABLE 2.4.1.1

#### 2.4.8 Motor Lock Protection

If a motor is locked, the FG1 signal is fixed at “H” or “L”. When the operating time (t1) passes in this state, the motor lock state is detected. Then all IGBTs (top and bottom arms) are turned off. After that, when the recovery time (t2) passes, the IC returns to the state in which the IGBTs operate depending on input signals.

The operating time and recovery time are adjustable by the capacitance of the external capacitor CM.

$$\text{Operating time: } t1(\text{s}) = \{TMLON(\text{ms})/1000\} \times \{CM(\text{pF})/1000(\text{pF})\}$$

$$\text{Recovery time: } t2(\text{s}) = \{TMLOFF(\text{ms})/1000\} \times \{CM(\text{pF})/1000(\text{pF})\}$$

If the motor takes long time to start up because of low Vs voltage or high-load, and so on, the motor lock state may be detected during motor start-up. Set the capacitance of the external capacitor CM considering star-up time variation.

The motor lock state is not detected under any of the following conditions (1) to (3).

- (1) VSP input voltage  $\leq$  typ. 2.2V
- (2) Vcc low-voltage detection operates.
- (3) Over temperature protection operates.

When the motor lock protection is not used, connect the CML pin to the GL pin.

#### 2.4.9 Over Temperature Protection

When IC temperature exceeds the operating temperature of over temperature protection (TSDON), all IGBTs (top and bottom arms) are turned off. When IC temperature goes below the recovery temperature of over temperature protection (TSDOFF), the IC returns to the state in which the IGBTs operate depending on input signals.

#### 2.4.10 Vcc Standby Function

When the input voltage at the VSP pin is more than the all off operating voltage (Voff, typ.1.23V), the current is applied from the HA pin to the Hall elements.

When the input voltage at the VSP pin is less than the all off operating voltage, the current to the Hall elements is shut off to reduce standby power consumption from Vcc power supply.

When the current to the Hall elements is shut off, the voltages at the Hall signal input pins (H\*P, H\*N) are fixed at “L”. At this time, the FG1 and the FG2 output “L”. If there is a need to confirm the motor rotating state through the FG1 or the FG2 output signal while the VSP input voltage is below the all off operating voltage, do not use this function (the HA pin). Use the CB pin as the power supply for the Hall elements.

When this function is not used, open the HA pin or connect it to the CB pin.

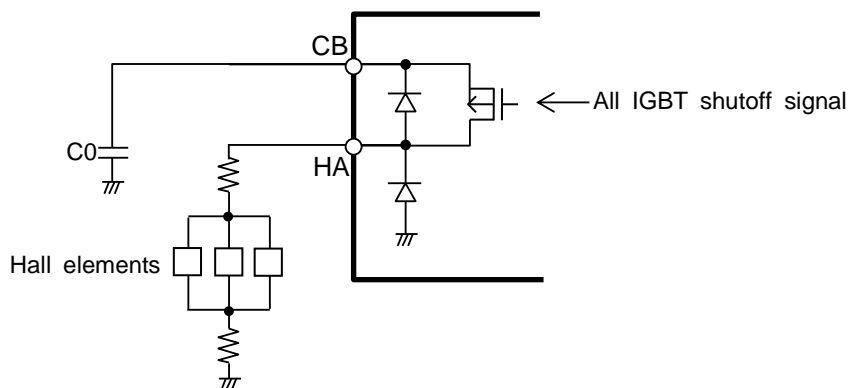

**FIGURE 2.4.10.1 Usage Example of Hall Elements and Internal Equivalent Circuit**

#### 2.4.11 Power On/Off Sequence-free

When the current at the output pins is below 1A, IGBT current saturation does not occur regardless of power on/off sequence of the Vcc power supply, Vs power supply and VSP input voltage.

However, be aware that when the Vs power supply is powered on after the Vcc power supply and VSP input voltage power on with the motor lock protection enabled, the motor may take long time to start up because the motor lock protection operates.

### 3. Standard Applications

#### 3.1 External Components

**TABLE 3.1.1 External Components**

Component	Standard value	Usage	Remark
C0	1.0μF±10%, 25V	Smooths the internal power supply (VB)	
CV1	1.0μF±10%, 25V	Smooths the Vcc power supply	Note 1
CV2	33nF±10%, 630V	Smooths the Vs power supply	Note 2
DZ	5W	Absorbs Vs line surge voltage	
C1, C2	0.22μF±10%, 25V	For charge pump	
C3, C4, C5	1000pF±10%, 25V	Eliminates Hall signal noise	Note 3
Rs	1Ω±1%, 1W	Sets current limit	Note 4
CTR	2200pF±5%, 25V	Sets PWM frequency	Note 5
RTR	11kΩ±5%		
CM	1.0μF±10%, 25V	For motor lock protection	
CF	470pF±10%, 25V	For over-current protection	
RF	2MΩ±10%		

Note 1: As necessary, increase the capacitance and add a zener diode in consideration of noise immunity.

Note 2: As necessary, increase the capacitance in consideration of noise immunity.

Note 3: Optimize the capacitance corresponding to conditions.

Note 4: The current limit set value can be calculated as follows.

$$I = V_{ref1} / R_s \text{ (A)}$$

To determine the shunt resistor Rs, see TABLE 3.1.1 and Section 4.

Note 5: The PWM frequency is approximated by the following equation.

$$f_{PWM} \cong 0.494 / (CTR \times RTR) \text{ (Hz)}$$

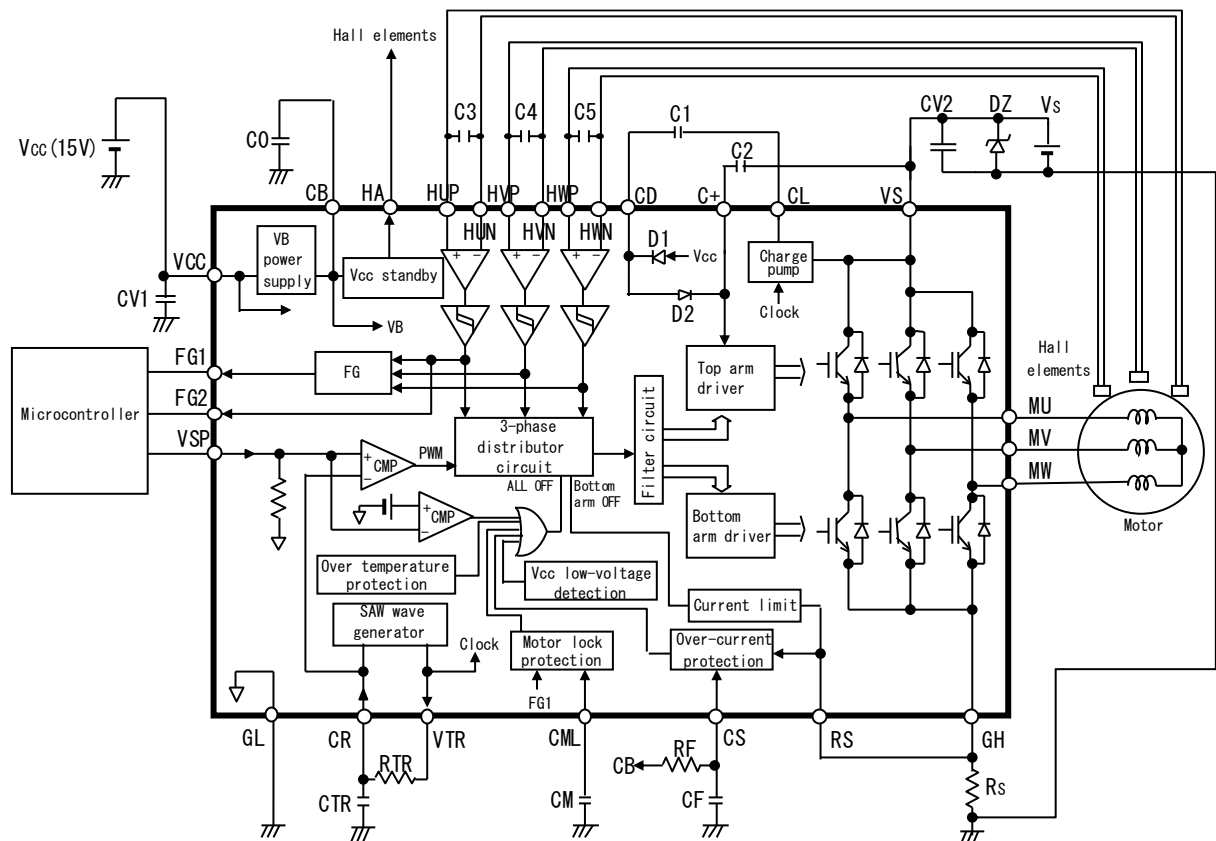

**FIGURE 3.1.1 Block Diagram (ECN30210S is shown inside the bold line.)**

#### 4. Safe Operation Area (SOA) and Derating

##### 4.1 Safe Operation Area (SOA)

The current and voltage at output pins must not be outside the SOA shown in FIGURE 4.1.1.

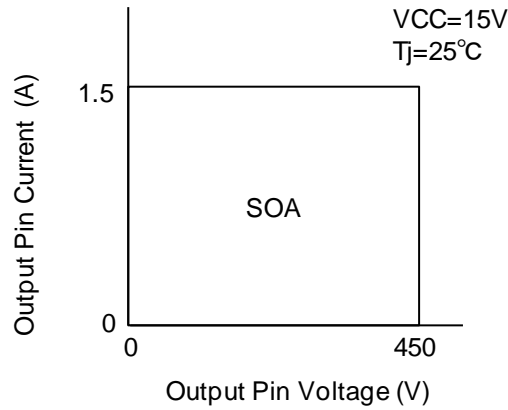

FIGURE 4.1.1 SOA

##### 4.2 Power On/Off Sequence and Current Derating for VCC Pin Voltage

The current derating for VCC pin voltage is shown in FIGURE 4.2.1. Use the output pin current below the derating curve. When the output pin current is less than 1A, power on/off sequence is free.

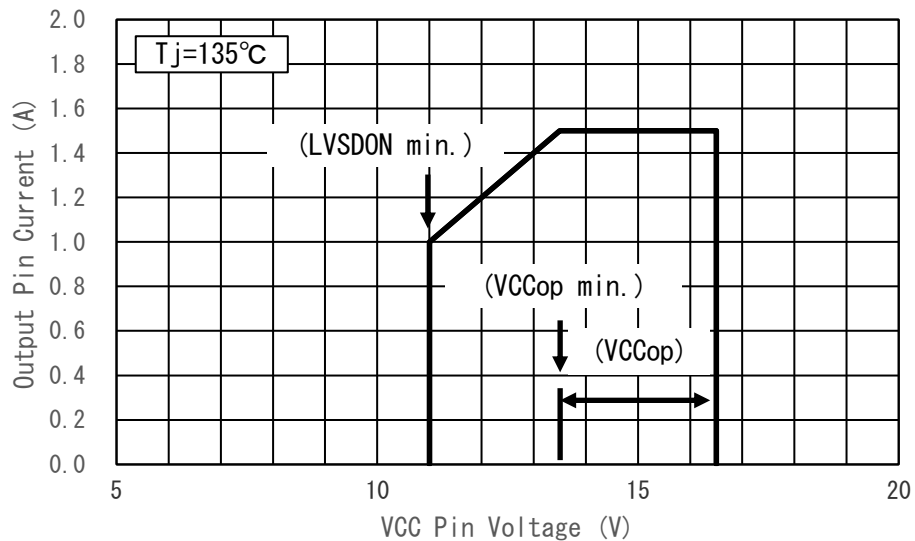
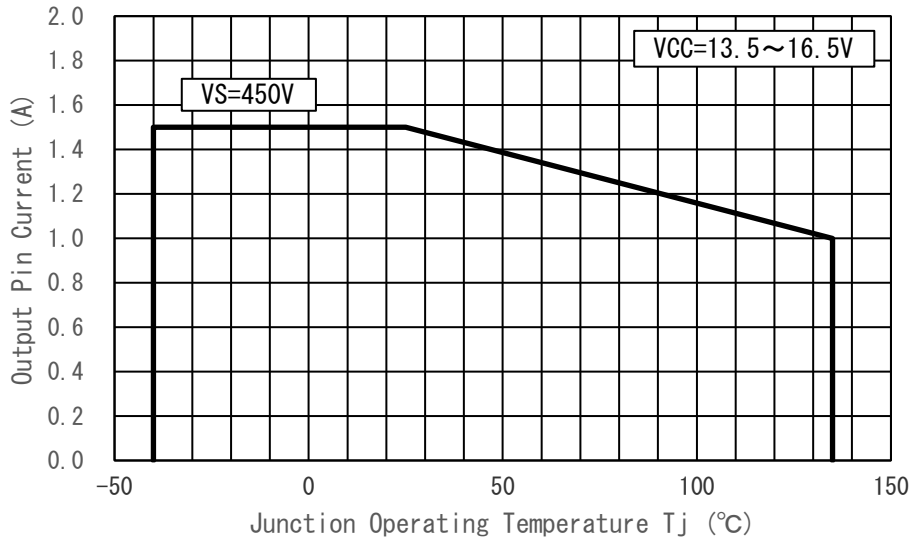

FIGURE 4.2.1 Current Derating for VCC Pin Voltage

#### 4.3 Current Derating for Junction Operating Temperature

The current derating for junction operating temperature is shown in FIGURE 4.3.1. Use the output pin current below the derating curve.



**FIGURE 4.3.1 Current Derating for Junction Operating Temperature**

#### 4.4 Shunt Resistor Setting

When setting the current limit, consider the variability of the reference voltage (Vref1), the variability of shunt resistor (Rs) and the delay time.

The current must be below the derating curves of FIGURE 4.2.1 and FIGURE 4.3.1.

#### 4.5 General Design Derating Standards

(a) Temperature - Junction operating temperature must be kept under 110°C.

(b) Supply voltage - Vs power supply voltage must be kept under 450V.

Junction operating temperature depends on various parameters such as power supply voltages, ambient temperature, load, heat dissipation routes. Test it sufficiently by using actual systems.

**5. Pin Locations**

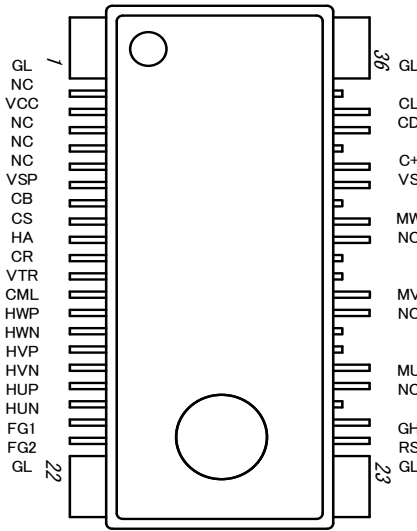

**FIGURE 5.1 Pin Locations (Top view)**

**6. Explanations of Pins**

**TABLE 6.1 Explanations of Pins**

Pin No.	Symbol	Explanation	Remark
1, 22, 23, 36	GL	Ground	
2, 4, 5, 6, 26, 28, 30	NC	No connection	Note 2
3	VCC	15V power supply	
7	VSP	Analog speed command signal input	
8	CB	VB power supply output	
9	CS	For over-current protection	
10	HA	Output for Vcc standby function	
11	CR	Connect a resistor and a capacitor to set the PWM frequency	
12	VTR	Connect a resistor to set the PWM frequency	
13	CML	For motor lock protection	
14	HWP	W phase Hall signal plus input	
15	HWN	W phase Hall signal minus input	
16	HVP	V phase Hall signal plus input	
17	HVN	V phase Hall signal minus input	
18	HUP	U phase Hall signal plus input	
19	HUN	U phase Hall signal minus input	
20	FG1	Output for motor rotational speed monitor (three pulses)	
21	FG2	Output for motor rotational speed monitor (one pulse)	
24	RS	Input for current limit and over-current protection	
25	GH	Emitters of bottom arm IGBTs and anodes of bottom arm FWDs (Connected to a shunt resistor)	
27	MU	U phase output	Note 1
29	MV	V phase output	Note 1
31	MW	W phase output	Note 1
32	VS	High voltage power supply	Note 1
33	C+	For the charge pump circuit	Note 1
34	CD	For the charge pump circuit	Note 1
35	CL	For the charge pump circuit	Note 1

Note 1: High voltage pin. The voltage between CD and CL and between C+ and VS are low. Therefore, the distances between these pins are the same as those between low voltage pins.

Note 2: Not connected to the chip in the IC.

## 7. Inspection

Hundred percent inspection shall be conducted on electric characteristics at room temperature. For the operating temperature and recovery temperature of the over temperature protection, equivalent inspections are conducted at room temperature.

## 8. Precautions for Use

### 8.1 Countermeasures against Electrostatic Discharge (ESD)

- (a) Customers need to take precautions to protect ICs from electrostatic discharge (ESD). The material of the container or any other device used to carry ICs should be free from ESD, which can be caused by vibration during transportation. Use of electrically conductive containers is recommended as an effective countermeasure.
- (b) Everything that touches ICs, such as the work platform, machine, measuring equipment, and test equipment, should be grounded.
- (c) Workers should be high-impedance grounded (100kΩ to 1MΩ) while working with ICs, to avoid damaging the ICs by ESD.
- (d) Friction with other materials, such as high polymers, should be avoided.
- (e) When carrying a PCB with a mounted IC, ensure that the electric potential is maintained at a constant level using the short-circuit terminals and that there is no vibration or friction.
- (f) The humidity at an assembly line where ICs are mounted on circuit boards should be kept around 45 to 75 percent using humidifiers or such. If the humidity cannot be controlled effectively, using ionized air blowers (ionizers) is effective.

### 8.2 Output Short-circuit Protection

Our IC could break by a short circuit (ex. load short). Therefore, external protection is needed.

### 8.3 Maximum Ratings

Regardless of changes in external conditions during use of our IC, the “maximum ratings” described in this document should never be exceeded when designing electronic circuits that employ our IC. If maximum ratings are exceeded, our IC may be damaged or destroyed. In no event shall our company be liable for any failure in our IC or any secondary damage resulting from use at a value exceeding the maximum ratings.

### 8.4 Derating Design

Continuous high-load operation (high temperatures, high voltages, large currents) should be avoided and derating design should be applied, even within the ranges of the maximum ratings, to ensure reliability.

### 8.5 Safe Design

Our IC may fail due to accidents or unexpected surge voltages. Accordingly, adopt safe design features, such as redundancy and measures to prevent misuse, in order to avoid extensive damage in the event of a failure.

### 8.6 Application

If our IC is applied to the following uses where high reliability is required, obtain the document of permission from our company in advance.

- Automobile, Train, Vessel, etc.

Do not apply our IC to the following uses where extremely high reliability is required.

- Nuclear power control system, Aerospace instrument, Life-support-related medical equipment, etc.

## 8.7 Soldering

### (1) Soldering Condition

The recommended reflow soldering condition is shown in FIGURE 8.7.1.

High stress by mounting, such as long time thermal stress by preheating, mechanical stress, etc., can lead to degradation or destruction. Make sure that your mounting method does not cause problem as a system.

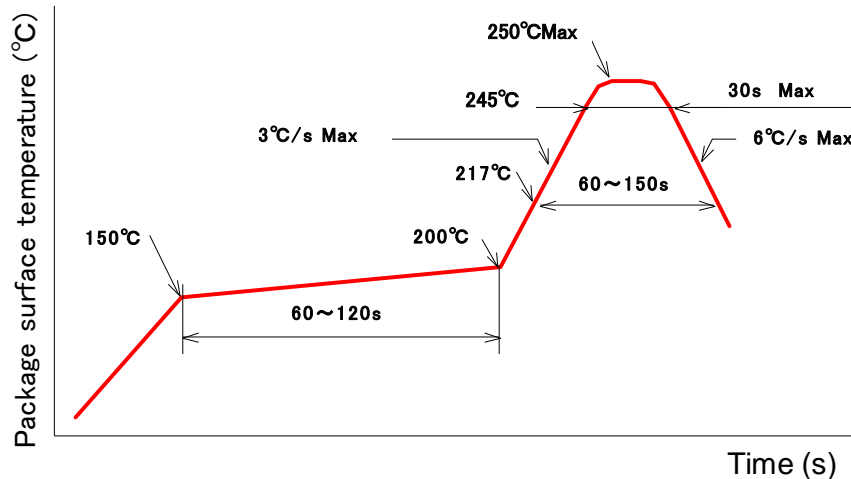

**FIGURE 8.7.1 Recommended Conditions for Infrared Reflow or Air Reflow**

### (2) Reliability of Solder Connection

The reliability of solder connection depends on soldering condition, materials of circuit boards, footprint, etc. Test it sufficiently by heat cycle test, heat shock test, and so on after mounting ICs on circuit boards.

## 8.8 Storage Conditions

### (1) Before opening the moisture prevention bag (aluminum laminate bag)

Temperature: 5 to 35°C  
Humidity: less than 85%RH  
Period: less than 2 years

### (2) After opening the moisture prevention bag (aluminum laminate bag)

Temperature: 5 to 30°C  
Humidity: less than 70%RH  
Period: less than 1 week (from opening the bag to reflow soldering)

### (3) Temporal storage after opening the moisture prevention bag

When ICs are stored temporarily after opening the bag they should be returned into the bag with desiccant within 10 minutes. Then, the open side of the bag should be folded under twice and closed with adhesive tape. And they should be kept in the following conditions.

Temperature: 5 to 35°C  
Humidity: less than 85%RH  
Period: less than 1 month

※ When the period of (1) to (3) is expected to expire, it is recommended to store the IC in a drying furnace (30%RH or lower) at ordinary temperature.



(4) Baking process

When the period of (1) to (3) has expired, the IC should be baked in accordance with the following conditions. (However, when the IC is stored in a drying furnace (30%RH or lower) at ordinary temperature, there is no need to bake.) Do not bake the tape and the reel of the taping package because they are not heat resistant. Transfer the IC to a heat resistant container prior to baking.

Temperature:  $125\pm 5^{\circ}\text{C}$

Period: 16 to 24 hours

8.9 Others

See "Instructions for Use of High-Voltage Monolithic ICs" and "Application Note" for other precautions and instructions on how to deal with these kinds of products.

## 9. Usage

- (1) Our company warrants that our products have the specified performance according to the respective specifications at the time of its sale. Testing and other quality control techniques of our products by our company are utilized to the extent we need to meet the specifications described in this document. Not every device of our products is specifically tested on all parameters, except those mandated by relevant laws and/or regulations.
- (2) Following any claim regarding the failure of a product to meet the performance described in this document made within one month of product delivery, all the products in relevant lot(s) shall be re-tested and re-delivered. Our products delivered more than one month before such a claim shall not be counted for such response.
- (3) Our company assumes no obligation nor makes any promise of compensation for any fault which should be found in a customer's goods incorporating the products in the market. If a product failure occurs for reasons obviously attributable to our company and a claim is made within six months of product delivery, our company shall offer free replacement or payment of compensation. The maximum compensation shall be the amount paid for the products, and our company shall not assume responsibility for any other compensation.
- (4) Our company reserves the right to make changes in this document and to discontinue mass production of the relevant products without notice. Customers are advised to confirm specification of the product of inquiry before purchasing of the products that the customer desired. Customers are further advised to confirm before purchasing of such above products that the product of inquiry is the latest version and that the relevant product is in mass production status if the purchasing of the products by the customer is suspended for one year or more.
- (5) When you dispose of our products and/or packing materials, comply with the laws and regulations of each country and/or local government. Conduct careful preliminary studies about environmental laws applying to your products such as RoHS, REACH. Our company shall not assume responsibility for compensation due to contravention of laws and/or regulations.
- (6) Our company shall not be held liable in any way for damages and infringement of patent rights, copyright or other intellectual property rights arising from or related to the use of the information, products, and circuits in this document.
- (7) No license is granted by this document of any patents, copyright or other intellectual property rights of any third party or of our company.
- (8) This document may not be reprinted, reproduced or duplicated, in any form, in whole or in part without the express written permission of our company.
- (9) You shall not use our products (technologies) described in this document and any other products (technologies) manufactured or developed by using them (hereinafter called "END Products") or supply our products (technologies) and END Products for the purpose of disturbing international peace and safety, including ( i ) the design, development, production, stockpiling or any use of weapons of mass destruction such as nuclear, chemical or biological weapons or missiles, ( ii ) the other military activities, or ( iii ) any use supporting these activities. You shall not sell, export, dispose of, license, rent, transfer, disclose or otherwise provide our products (technologies) and END Products to any third party whether directly or indirectly with knowledge or reason to know that the third party or any other party will engage in the activities described above.  
When exporting, re-export transshipping or otherwise transferring our products (technologies) and END Products, all necessary procedures are to be taken in accordance with Foreign Exchange and Foreign Trade Act (Foreign Exchange Act) of Japan, Export Administration Regulations (EAR) of US, and any other applicable export control laws and regulations promulgated and administered by the governments of the countries asserting jurisdictions over the parties or transaction.

◆ Appendix - Supplementary Data

1. Dimensions

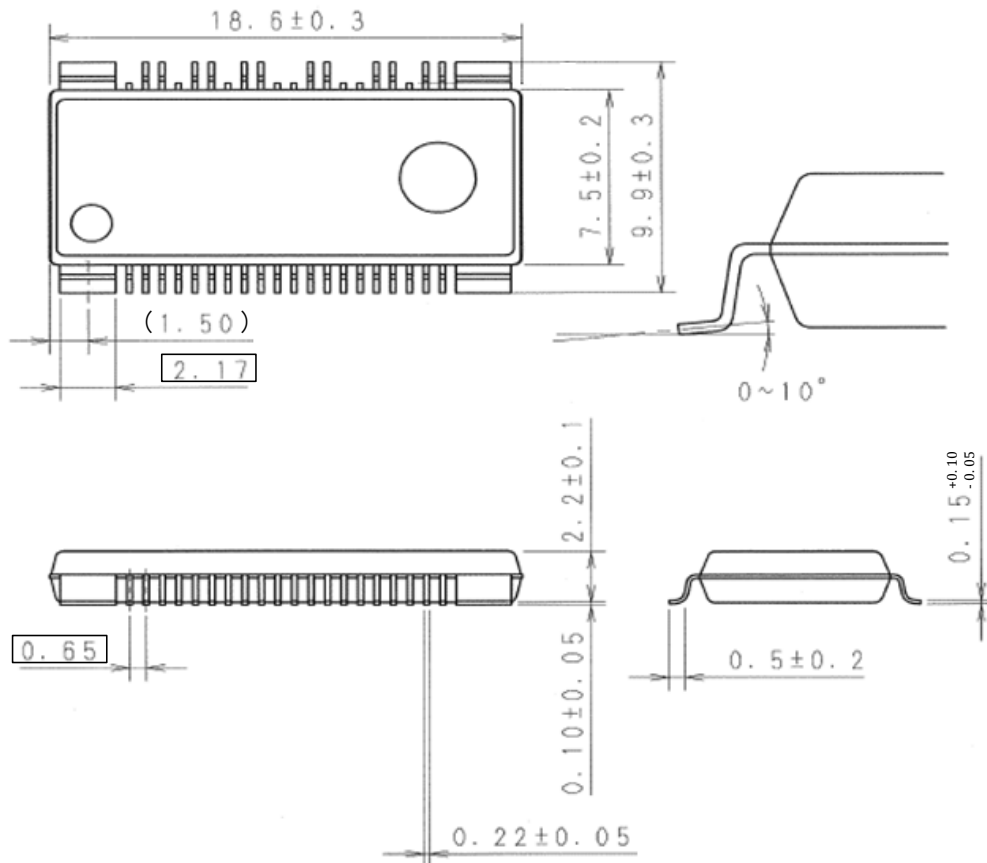

Unit: mm

FIGURE A: Dimensions

## 2. External Packaging

### 2.1 External Packaging

FIGURE B shows the external packaging. Order quantities are basically multiples of 2000.

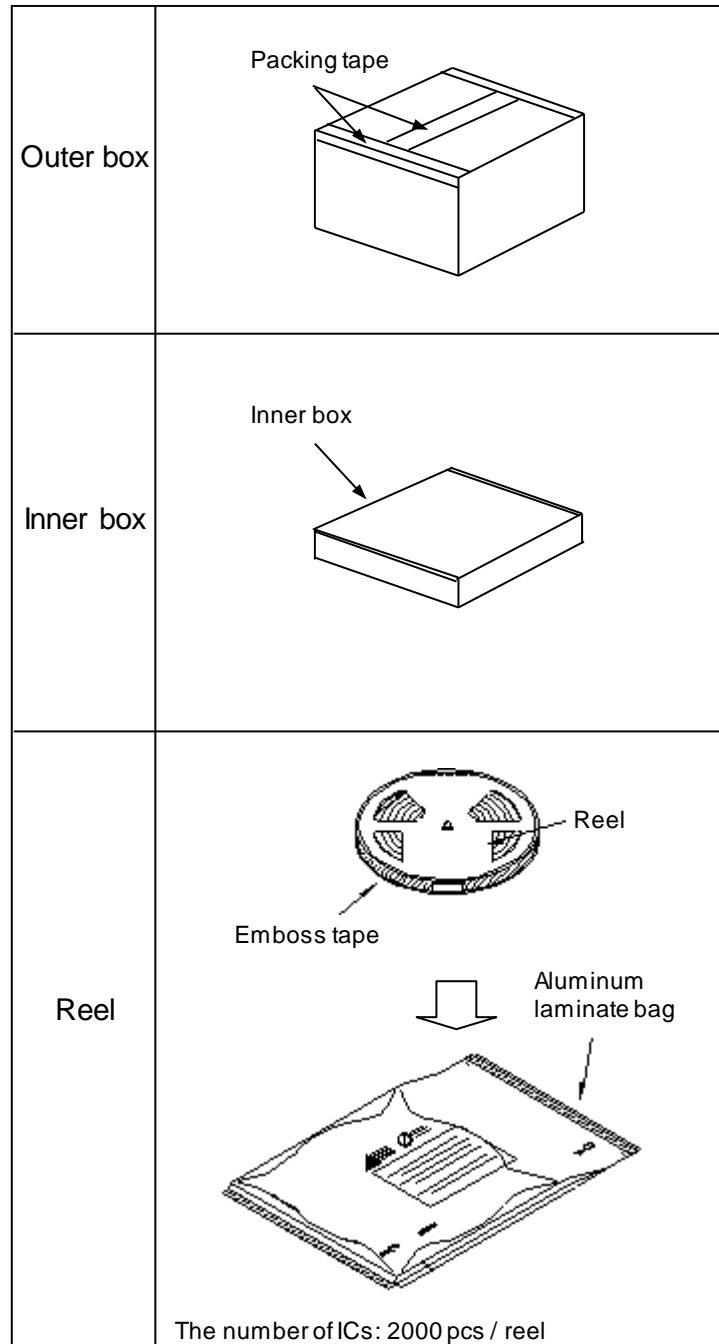

**FIGURE B: External Packaging**

---

## Precautions for Safe Use and Notices

---

If semiconductor devices are handled in an inappropriate manner, failures may result. For this reason, be sure to read the latest version of "Instructions for Use of High-Voltage Monolithic ICs" before use.



This mark indicates an item requiring caution.



**CAUTION** This mark indicates a potentially hazardous situation which, if not avoided, may result in minor or moderate injury and damage to property.



### CAUTION

- (1) Regardless of changes in external conditions during use of semiconductor devices, the "maximum ratings" and "safe operating area(SOA)" should never be exceeded when designing electronic circuits that employ semiconductor devices.
- (2) Semiconductor devices may fail due to accidents or unexpected surge voltages. Accordingly, adopt safe design features, such as redundancy and measures to prevent misuse, in order to avoid extensive damage in the event of a failure.
- (3) If semiconductor devices are applied to uses where high reliability is required, obtain the document of permission from MPSD in advance (Automobile, Train, Vessel, etc.). Do not apply semiconductor devices to uses where extremely high reliability is required (Nuclear power control system, Aerospace instrument, Life-support-related medical equipment, etc.).  
(If a semiconductor device fails, there may be cases in which the semiconductor device, wiring or wiring pattern will emit smoke or cause a fire or in which the semiconductor device will burst.)

---

## NOTICES

---

1. This Data Sheet contains the specifications, characteristics, etc. concerning power semiconductor products (hereinafter called "products").
2. All information included in this document such as product data, diagrams, charts, algorithms, and application circuit examples, is current as of the date this document is issued. Such information, specifications of products, etc. are subject to change without prior notice. Before purchasing or using any of the MPSD products listed in this document, please confirm the latest product information with a MPSD sales office.
3. MPSD shall not be held liable in any way for damages and infringement of patent rights, copyright or other intellectual property rights arising from or related to the use of the information, products, and circuits in this document.
4. No license is granted by this document of any patents, copyright or other intellectual property rights of any third party or of MPSD.
5. This document may not be reprinted, reproduced or duplicated, in any form, in whole or in part without the express written permission of MPSD.
6. You shall not use the MPSD products (technologies) described in this document and any other products (technologies) manufactured or developed by using them (hereinafter called "END Products") or supply the MPSD products (technologies) and END Products for the purpose of disturbing international peace and safety, including ( i ) the design, development, production, stockpiling or any use of weapons of mass destruction such as nuclear, chemical or biological weapons or missiles, ( ii ) the other military activities, or ( iii ) any use supporting these activities. You shall not sell, export, dispose of, license, rent, transfer, disclose or otherwise provide the MPSD products (technologies) and END Products to any third party whether directly or indirectly with knowledge or reason to know that the third party or any other party will engage in the activities described above.  
When exporting, re-export transshipping or otherwise transferring the MPSD products (technologies) and END Products, all necessary procedures are to be taken in accordance with Foreign Exchange and Foreign Trade Act (Foreign Exchange Act) of Japan, Export Administration Regulations (EAR) of US, and any other applicable export control laws and regulations promulgated and administered by the governments of the countries asserting jurisdictions over the parties or transaction.
7. In no event shall MPSD be liable for any failure in MPSD products or any secondary damage resulting from use at a value exceeding the maximum ratings.

Refer to the following website for the latest information. Contact a MPSD sales office if you have any questions.

<https://www.minebea-psd.com/en>